



X SYSTEM[®]

COACHCOMM

OPERATING MANUAL X2 PACKAGE



This page is intentionally blank.

Thank you from CoachComm!

We at CoachComm want to thank you for purchasing a CoachComm X-System Sideline Communications System. We have made every effort to build a reliable, intuitive communication system that provides the functionality that you can count on come game day.

One of our goals in the design of the CoachComm X-System was to build on the advances set forth by the previous Tempest® NG System and to provide users with unmatched RF performance. You will be able to begin using your new X-System with nothing more than the Game Day Guide. However, to fully benefit from the available features, please read this manual carefully.

We want X-System to make your job easier and your game day experience positive. To successfully familiarize yourself with the many diverse and powerful features X-System offers, it is crucial that you acquaint yourself with the manual.

We are committed to providing you with a high quality product that will deliver years of trouble-free service. Should you experience any problem with your CoachComm X-System equipment, whether it is under warranty or not, we will do our best to take care of your needs.

Thank you for choosing CoachComm for your sideline communication needs.

CoachComm LLC
205 Technology Parkway
Auburn, AL 36830
Phone: 334-321-2300
Fax: 888-329-2658
www.coachcomm.com

© 2018-2026 CoachComm LLC. All rights reserved.

Document Reference: D0000383_N

© Telex is a registered trademark of Telex Communications, Inc.

© Audiocom is a registered trademark of Bosch Security Systems, Inc.

Table of Contents

- Safety Information1
 - Electrical Safety.....1
 - Battery Safety.....2
 - Protecting Yourself and Those Around You2
- Introduction3
 - What makes X-System so different?3
 - Frequency Considerations.....3
- New in Version 1.214
 - CoachComm X-System Player Mini.....4
- X2 Block Diagram5
- Game Day Setup6
- X-System Components10
 - X2 Package Overview10
 - Press Box Rack Unit Overview11
 - Wired Interface (WI)12
 - Control Unit (XCU-44).....14
 - Radio Transceiver (XRT-900 and XRT-2400)19
 - Wired BeltPacks (X-WBP2-01)21
 - Radio Packs (XRP-13, XRP-22, and XRP-44)22
- System Accessories30
 - Press Box Cables.....30
 - Headsets30
- System Setup and Operation.....31
 - Mounting RTs31
 - Covering Your RTs.....33
 - Setting Home/Away Status33
 - Changing Conference Port Assignments.....34
 - Assign Profiles from the Control Unit.....34
 - Walk Testing Your System35
 - Understanding Link Quality35
- X-Ware Setup and Installation36
 - What You Will Need.....36
 - Installing and Updating X-Ware.....36
 - Updating Device Firmware.....39
 - Connecting X-Ware to Your CU.....41
- X-Ware43
 - Home Screen.....43
 - RP Icons45
 - Profile Screen.....47
 - Additional System Views.....49
 - X-Ware Advanced Settings.....54
 - Operational Modes62
- System Configuration File65
 - Saving a Configuration File65
 - Uploading a Configuration File65

System Maintenance	68
Basic Maintenance	68
Lithium-Polymer Battery Maintenance	68
Troubleshooting Common Issues.....	69
Product Support.....	70
Returning Equipment for Repair or Maintenance	70
License Information	71
Radio Device License Information	71
Non-Radio-Device License Information	72
X-Ware™ End User License Agreement (EULA)	73
Warranty Information	76
Limited Warranty	76
Parts Limited Warranty	76
Glossary	77
Specifications	78
Control Unit Specifications	78
Radio Transceiver Specifications	79
Radio Pack Specifications.....	80
Appendix A: CoachComm X-System Coach to Player Communication	83
Important Safety Information	84
CoachComm X-System Player Module	85
X-System Referee Cutoff	91
Appendix B: All Wireless Press Box.....	97
System Deployment - Radio Transceiver (RT)/Antenna Placement.....	97

Safety Information

The following pages detail important safety information related to the ownership and operation of CoachComm's X-System. Please ensure all personnel review the warnings and safety recommendations included in this document before operating X-System in order to prevent equipment damage and/or serious personal injury.

Throughout this document you will see the following indicators for important safety information and alerts:



WARNING: Ignoring these warnings may cause permanent or serious injury or death as a result of incorrect operation.



CAUTION: Ignoring these cautions may cause moderate injury or property damage as a result of incorrect operation.

Electrical Safety



WARNING: ELECTRIC SHOCK RISK

- » Do not submerge any part of X-System in water.
- » Refer all servicing to qualified service personnel. Do not attempt to modify, disassemble, or open any X-System components. Exposing the electrical system may result in equipment damage and serious personal injury, including electric shock. Equipment damage caused by unqualified personnel may void the product warranty associated with your X-System.



CAUTION: SYSTEM DAMAGE RISK

- » Protect the power cords from foot traffic. Do not allow cords to be crimped or pinched, particularly at plugs, electrical outlets, and the point they exit from the apparatus. Routinely inspect power cords for any signs of fray or extensive wear. Immediately replace any damaged cords.
- » Keep all ventilation openings clean and unobstructed. Failure to do so could cause the system to overheat, which could cause personal injury or property damage.
- » Unplug X-System during lightning storms to prevent power surges that could damage electrical components or cause fire.
- » In order to prevent voltage drop and damage to the system, a 3-wire grounded heavy-duty extension cord is required for use. CoachComm recommends using a cord 25 feet or less in total length for optimal performance.

Battery Safety

Radio Pack (RP) Battery Safety



WARNING: EXPLOSION AND FIRE RISK

- » Battery explosion is possible if incorrect type is used. Use only batteries approved for use with X-System Radio Packs. If powering the Radio Pack with AA batteries, use only alkaline or carbon-zinc batteries.
- » Do not leave the battery unattended while charging. Immediately unplug unit if battery begins to swell or emit smoke while charging. If battery bursts or chemicals begin to leak out of battery housing, the chemicals will react with the air and cause a fire.
- » CoachComm recommends keeping a Class-D fire extinguisher available when charging lithium-polymer batteries. The chemicals inside lithium-polymer batteries are highly flammable.
- » Do not allow batteries to overheat (reach temperatures of above 140 degrees Fahrenheit).
- » Batteries that appear swollen, deformed, or damaged, or that do not fit properly should never be used. Properly dispose of any batteries in this condition in accordance with the instructions provided by your local authorities. For more information and local drop-off sites, visit <https://www.call2recycle.org/>.

Protecting Yourself and Those Around You

Allow only responsible individuals who are familiar with these general safety rules and operating instructions to use your X-System. Never allow people unfamiliar with these rules and instructions to set up or operate your system.



CAUTION: SYSTEM DAMAGE AND INJURY RISK

- » Never, under any conditions, remove, bend, cut, fit, weld, or otherwise alter standard parts of the X-System. Modifications to your system could cause personal injuries and property damage and will void your warranty.
- » Only use attachments/accessories/cables/antennas/hardware provided by the manufacturer.
- » Do not remove or cover any safety labels. If a label is damaged or removed, contact a CoachComm support technician for a replacement.
- » Do not mount the Radio Transceiver/Antenna suction cup directly over heads, if possible. If unavoidable, it is imperative that you use the included safety lanyard to secure the suction cup to a fixed anchor point to prevent damage or injury from falling objects.

WARNING

1. Read all instructions and warnings before mounting RTs.
2. You must properly mount this equipment before use.
3. Only authorized individuals allowed to operate equipment.
4. Ignoring the warnings may cause serious injuries or death.

Introduction

What makes X-System so different?

CoachComm has been building and providing wired and wireless systems for over 25 years to supply quality communications and practice equipment to every level of football nationwide. Championship-winning teams have found confidence in our Tempest FX system, Connex system, and most recently our X-System. Our latest solution combines the mobility and functions you're familiar with from Tempest FX and pairs it with our latest development in design and agility from the X-System.

X-System makes use of the newest available communications technology and meets our customers' demands for more users, better audio, and future-based features.

X-System is the first wireless communications system to innovate the following unique features:

- Better Frequency-Hopping Spread Spectrum performance in dome venues
- Enhanced 900MHz wireless performance
- Better 7k audio quality
- X-Ware software user interface for monitoring and customizing the X-System

These features come together to form a powerful product called X-System. X-System, together with enhanced tools for the wired portion of the system, makes for an incredibly robust, easy-to-operate system.

Frequency Considerations

900MHz

CoachComm designed the new X-System to operate seamlessly in the 900MHz frequency band. This allows multiple devices to operate within the band with minimal interference or reduction of range and performance.

The 900MHz ISM frequency band is a portion of the RF spectrum available for unlicensed use in North America and other various locations with no frequency coordination. In North America, the 900MHz band is 902–928 MHz. X-System utilizes up to 26 MHz of this spectrum.

Frequency-Hopping Spread Spectrum

Frequency-Hopping Spread Spectrum (FHSS) is a means of RF transmission. In FHSS, the signal hops to various frequencies—hence the name. In doing so, it spreads the data (voice in our case) across a wide area of the RF spectrum. Devices such as those in X-System collide constantly with other devices in that frequency spectrum and must have mechanisms built into their protocol to allow for data redundancy to provide acceptable user performance.

New in Version 1.21

CoachComm X-System Player Mini

The new XRP-CP01M-900 Player-worn Radio Pack Mini Module can be added as an upgrade package to the X-System line that will allow for coaches to communicate with players either in a practice or game day environment. Its small size, robust housing, and simple interface allow it to be placed where needed. Integration into the X-System is seamless as software connectivity will allow for full control and routing of audio from coaches to players as needed.

See “Appendix A: CoachComm X-System Coach to Player Communication” on page 83 for more information about the X-System Player Upgrade.

Note: *Products and software associated with X-System Player and Referee Interrupt are only functional with the X-System Player upgrade package.*

X2 Block Diagram

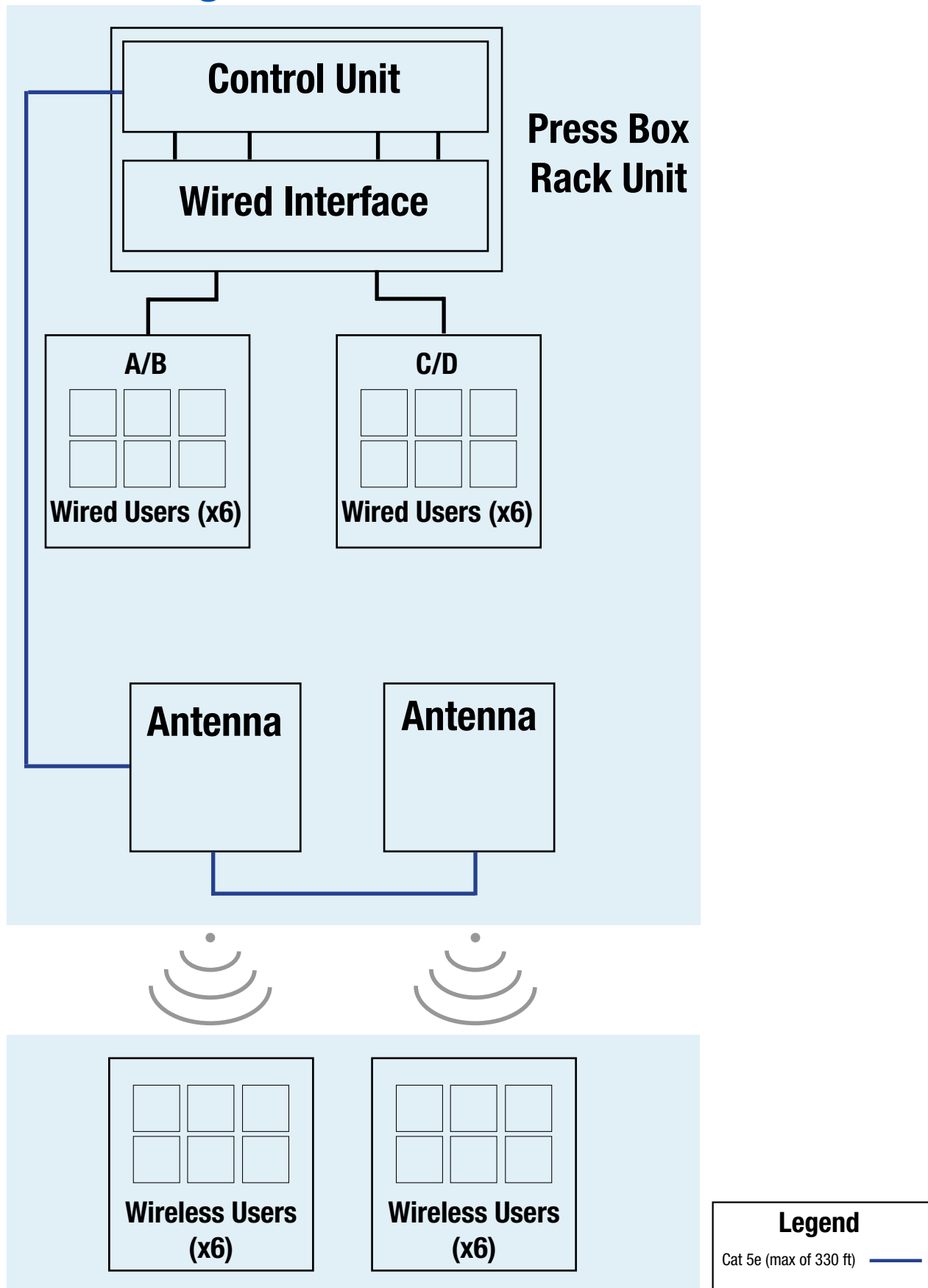

Figure 1: X2 Block Diagram

Game Day Setup

The procedures in this section serve as a reference for a typical game day setup. You can find more in-depth information about the devices and processes mentioned here in later sections of this Operating Manual.



CAUTION: Allow only responsible, authorized individuals who have read all of the instructions and warnings to set up and operate your X-System.

1. Set up Press Box Rack Unit.

- 1a. Unpack the press box and accessory cases.
- 1b. Position the Press Box Rack Unit out of the way to avoid coaches and other traffic.
- 1c. Connect power to the Press Box Rack Unit, but do NOT turn on the Control Unit (CU) yet. The “Power” LED on the front of the Wired Interface should be lit green.

Important: X-System requires a minimum of one dedicated 15 amp 120V circuit.

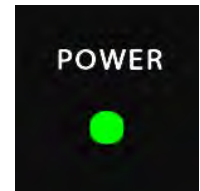

Figure 2: Power LED

2. Mount and connect the RT.

- 2a. Remove bracket (center antenna attached already) and two outer antennas from the Press Box Case.
- 2b. Align two outer antennas with bracket holes and fasten with thumb screws.
- 2c. Using either the clamp or suction cup mounting hardware, secure the RT bracket so that the RT’s logo points toward the center of your team’s coaches’ box. See page 31 of this manual for more instructions if needed.

Note: Any obstructions between the RT and field (like window tinting) can negatively impact performance. CoachComm recommends opening windows or mounting the RT externally to the press box. We also recommend covering RTs with a clear plastic bag or a rain cover in the event that rain is expected.

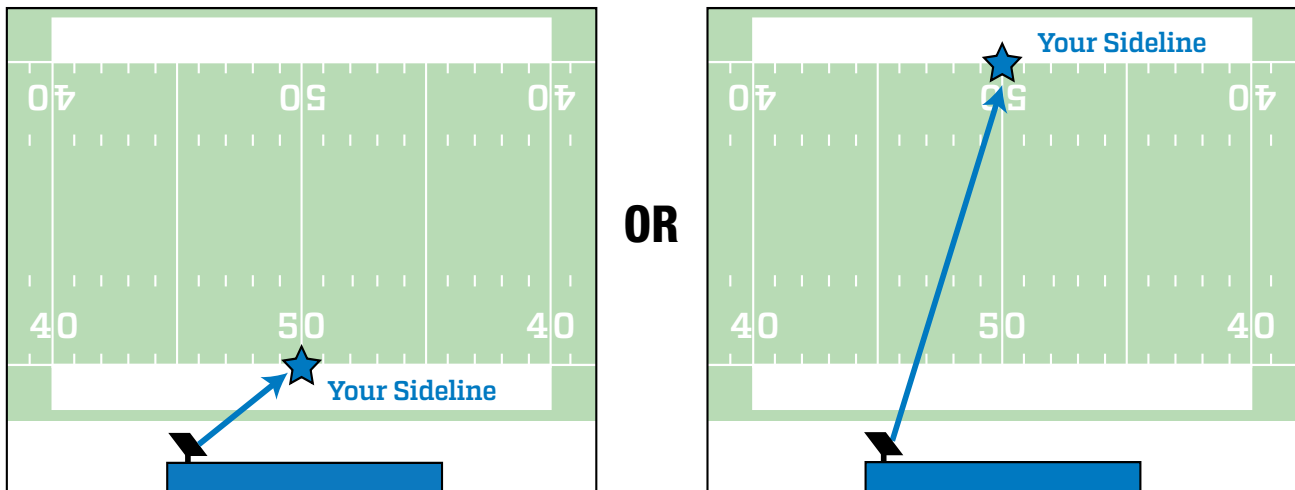

Figure 3: RT Pointed Toward Center of Your Team's Coaches' Box

- 2d. Connect a Cat 5 cable to the X-NET IN port on the RT.
- 2e. Connect the other end of the Cat 5 cable to the FIELD ANTENNA port on the Press Box Rack Unit's rear panel.
- 2f. If using a second field RT, confirm the short Cat 5 cable is properly connected between the first RT's RT LOOP port and the second RT's X-NET IN port.

Note: If applicable, a third RT for booth wireless can be connected as outlined in the diagram below.



CAUTION: Secure and protect any cords to prevent walkway hazards and potential contact with moisture.

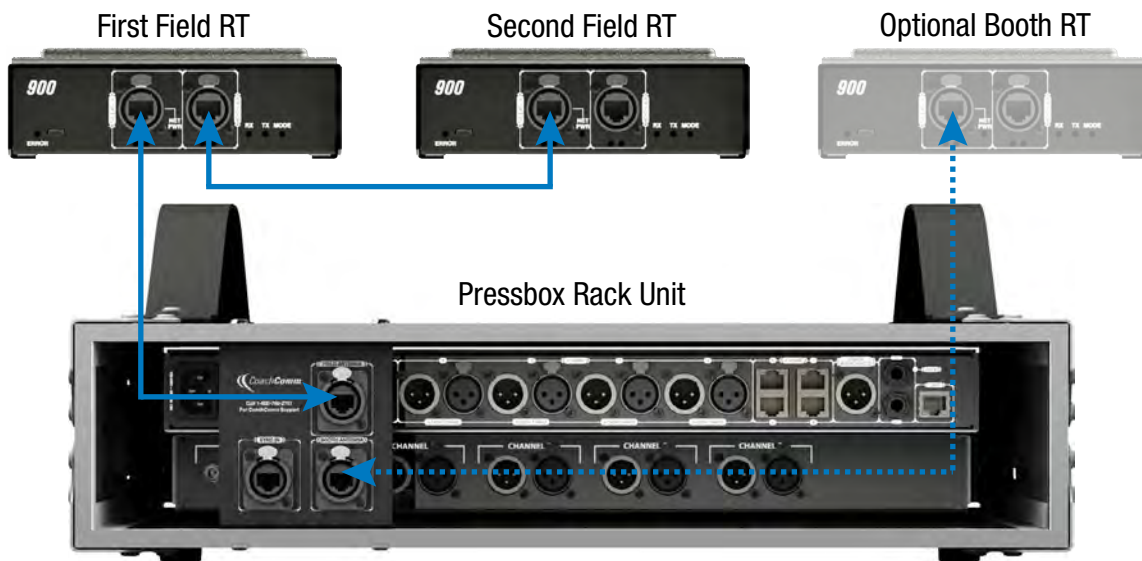

Figure 4: Press Box Rack Unit Connections to RTs

3. Power on the Control Unit.

- 3a. Power ON the CU via the power switch on its front panel.
- 3b. Use CU navigational controls to select **Home** or **Away** and press the Enter button.

Important: No RF transmission will occur until the Home/Away status is selected. Failure to set this status properly may result in RF interference if and when the opposing team is also using an X-System. It is important to coordinate with opponents to ensure optimal performance for both teams.

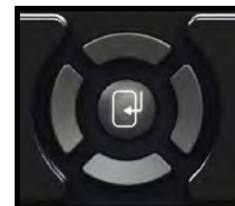

Figure 5: CU Navigation Buttons

- 3c. Wait until the CU displays the "CCF Loaded" message along with a configuration file summary. When the CCF load is complete, the home screen will display on the front of the CU and you can proceed.

CCF Loaded			
Version: 3	Flags: 02	Length: 3,936	Number of Devices: 3
Device Connection: 2	Control Unit: 1	Expansion: 0	Hub: 0
Radio Transceiver: 2	Radio Pack: 12	Radio Pack Profile: 12	
Conference: 4	Relay Assignment: 0	Aux Audio Assignment: 0	
User Info Record: 0	Access Rights: 0	UI Data: 0	

Figure 6: Sample CCF Loaded Screen

4. Set up the Wired Interface and Wired BeltPacks.

The procedures in this step should be performed with at least two people.

- 4a Place a Wired BeltPack at each coach's position in the press box.
- 4b Connect the short end of the Cat 5 cable bundle to the desired channels on front of the Wired Interface (A/B or C/D).
- 4c. Connect the opposite ends of the bundled cables to each Wired BeltPack.

Important: Keep cables out of the way of coaches and heavy foot traffic. Cables that are pinched, snagged, or damaged will cause disrupted communication.

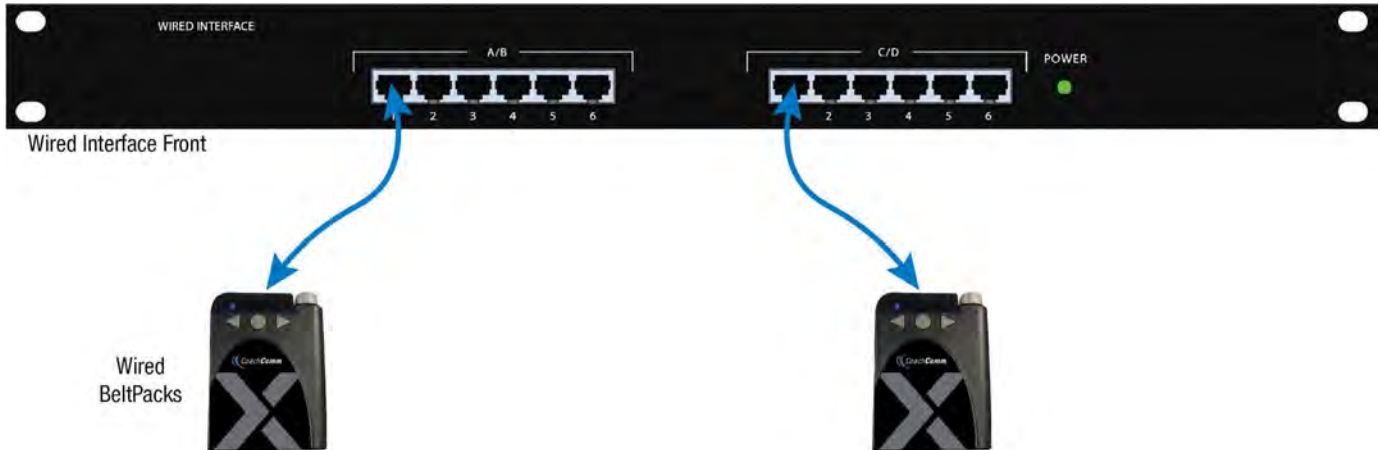

Figure 7: Wired Interface Connection to Wired BeltPacks

- 4d. Connect a headset to each Wired BeltPack.
- 4e. Power on each Wired BeltPack by turning the volume knob clockwise. The lights on the front of the BeltPack will illuminate when powered on. Confirm that each Talk button is off.
- 4f. Put on one headset and press the Talk button on the Wired BeltPack and confirm that you can communicate with a second Wired BeltPack on both channels with no crosstalk. Repeat the test for each Wired BeltPack.

5. Power on and walk test Radio Packs and Player Modules.

The procedures in this step should be performed with at least two people.

- 5a. Install a fully charged Lithium-Polymer rechargeable battery or three AA alkaline batteries in each Radio Pack (RP).
- 5b. Power on the first two RPs by pressing and holding the Power button on the back of the RP for 3 seconds.
- 5c. Confirm each RP is on the same conference, connect a headset to each RP, and conduct a walk test to confirm their operation. The RP's LQ value can be used to gauge performance.

Important: Each tester should walk their RPs to opposite goal lines and back, ensuring clear communication between all RPs. Always place the RP on the hip opposite from the press box when walk testing.



Figure 9: RP Battery Installation and Power On

5d. After walk testing is complete, place the RP down on a table or bench. Be sure to place each RP a foot or so apart; bunching RPs together could impact wireless performance. Repeat steps 5b-5c for each of the remaining RPs.

Important: If raining, cover the RPs or return them to their drawer.

5e. Connect batteries and speakers to all CoachComm X-System Player Modules to turn them on. Walk test the entire field. Repeat walk test for all remaining Player Modules.

Important: Player Modules should be over shoulder height for walk test.

5f. Confirm communication between wireless and wired coaches.

6. Power off and stow away.

Once your game has ended, power off and properly stow away all components:

6a. Power off all RPs and stow them with the field headsets in the sideline case.

6b. Power off and disconnect all Wired BeltPacks and stow them in the press box case.

6c. Power off the CU and disconnect the Cat 5 cable between the Press Box Rack Unit and the RTs.

6d. Carefully disassemble the two outer antennas and mounting hardware.

6e. Stow the two outer antennas, bracket with middle antenna, and mounting hardware in the appropriate case.

6f. Coil all cables and stow them with the press box headsets in the accessory case.

6g. Disconnect power from the Press Box Rack Unit and stow it in the press box case.

Important: Thoroughly dry off any moisture prior to storage. Failure to do so can cause components to corrode and damage.

X-System Components

X2 Package Overview

The X2 package for X-System consists of three cases that provide storage for the sideline and press box components of the system. The press box case and accessory case should be placed in the applicable press box for your team. The sideline case should be placed on your team's sideline. Further instructions about setting up your system are provided in the Game Day Setup section of this manual on page 5.



Wired BeltPacks



OR

Radio Pack

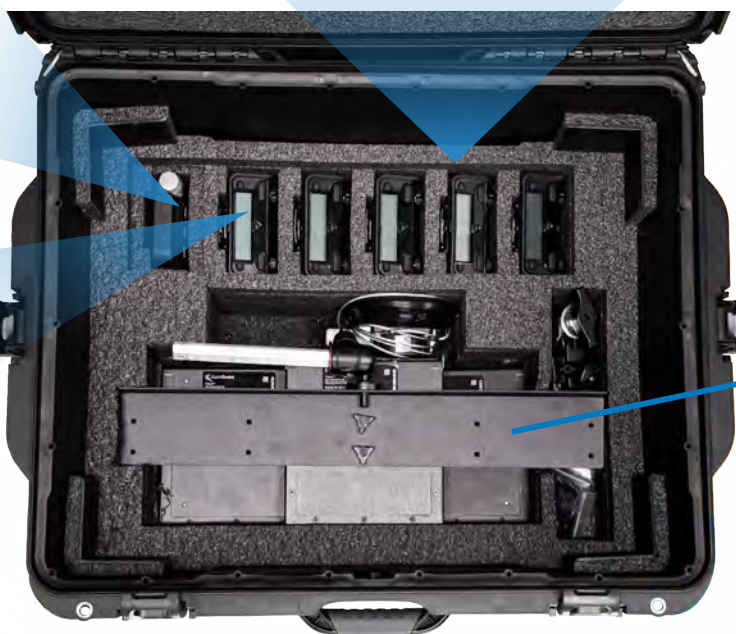

Press Box Case

***Note:** Spare lithium batteries are not allowed in checked airline baggage. Be sure to follow all air travel rules and regulations when traveling with your X-System.

Note: The Wired Interface is not used in X2 All Wireless systems.

Accessory Case

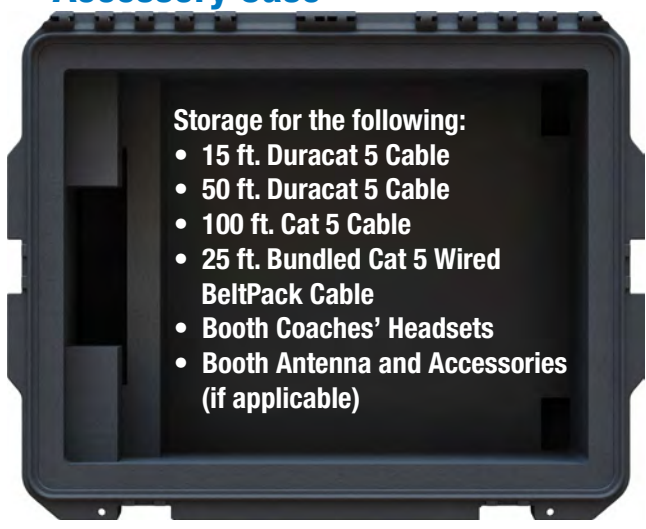

Sideline Case

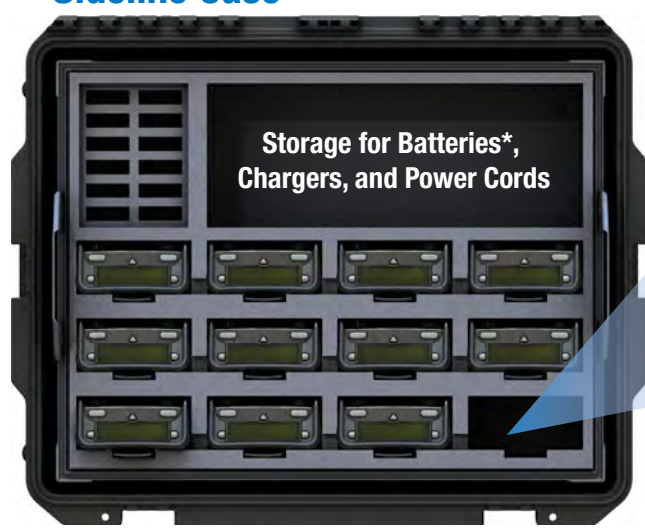

Radio Pack



(Sideline headset storage in bottom)

Press Box Rack Unit Overview

The Press Box Rack Unit houses the system’s Wired Interface, Control Unit, and RT connection panel. See page 12 of this manual for more information about the Wired Interface, and see page 14 for more information about the Control Unit.

Press Box Rack Unit Rear

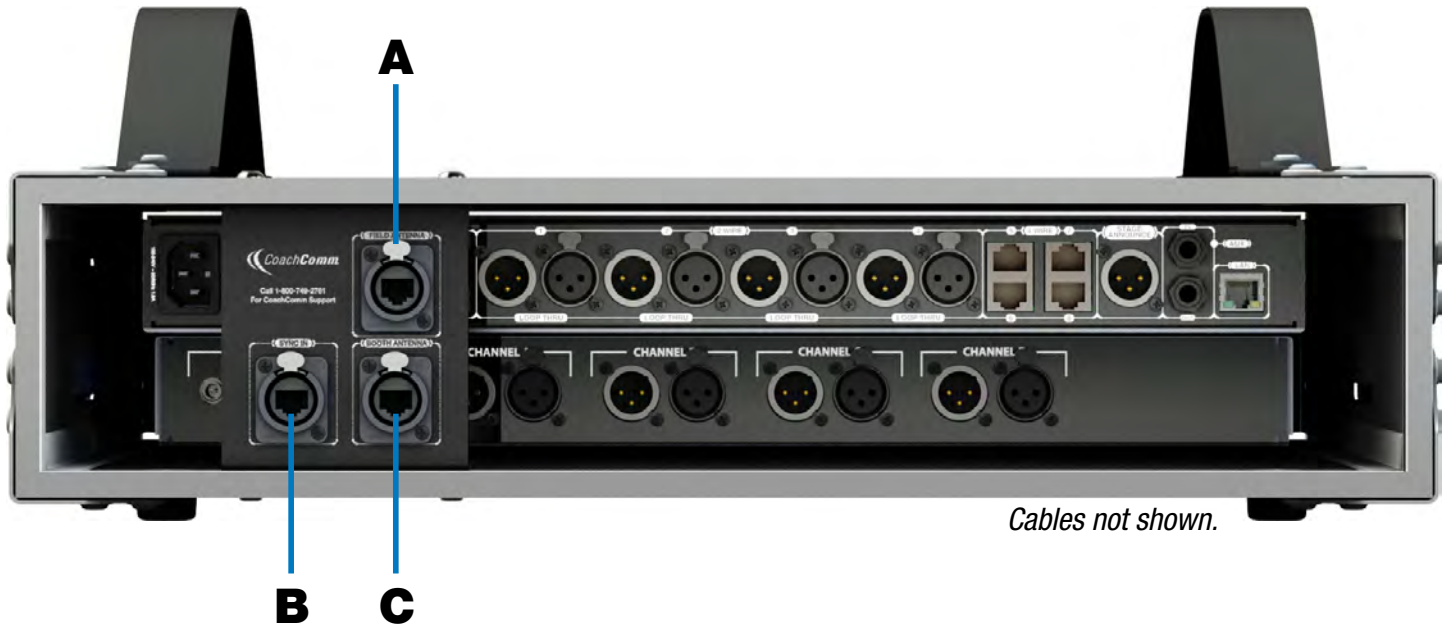

Figure 10: Press Box Rack Unit Rear View

- A. **FIELD ANTENNA Port** – Connection for the Cat 5 cable from the field RT(s).
- B. **SYNC IN Port** – Allows the system to be synchronized with another X-System. Sync is recommended when more than two unsynchronized X-System RTs are operating in close proximity to one another.
- C. **BOOTH ANTENNA Port** – Connection for the Cat 5 cable from a booth RT.

Note: Audio and power cables are not pictured in Figure 10.

Find more information about connecting RTs to the system on pages 6 and 31 of this manual.

Wired Interface (WI)

The Wired Interface (WI) is located in the main rack unit in the press box with the Control Unit (CU). The interconnectivity between the WI and the CU is pre-wired at CoachComm.

Wired Interface Front

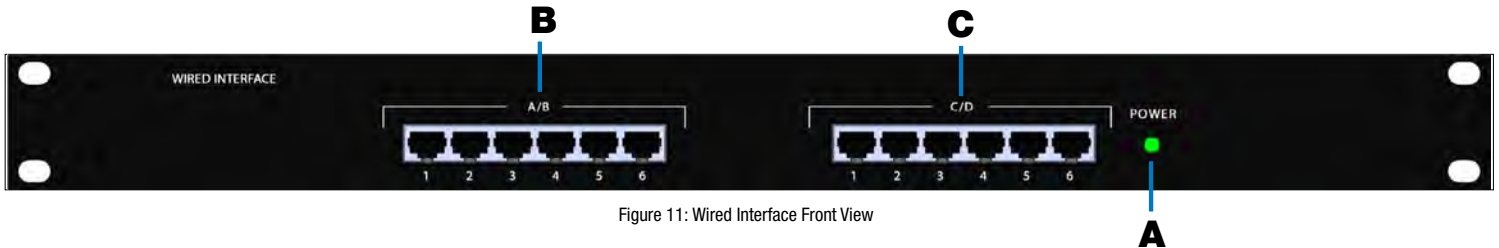

Figure 11: Wired Interface Front View

- A. Power LED
- B. Channel A/B Ports
- C. Channel C/D Ports

Wired Interface Rear

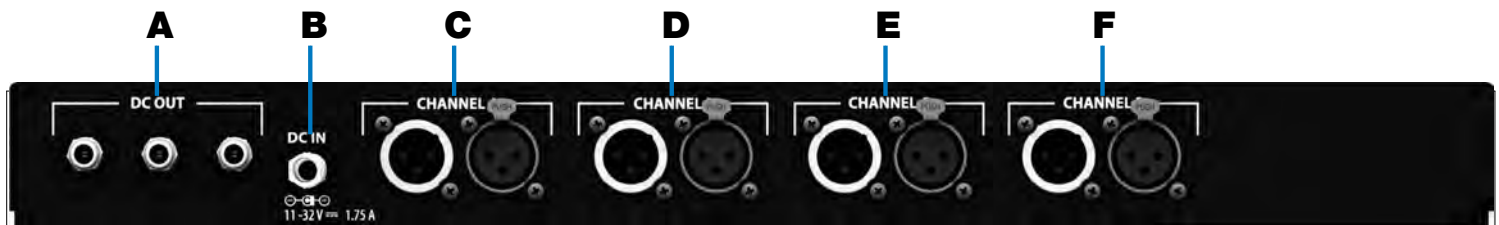

Figure 12: Wired Interface Rear View

- A. DC Power Out – Not currently used with X-System operation
- B. DC Power In
- C. Channel A XLRs – Connects Wired Interface Port A to Port 2-Wire 1 of the Control Unit
- D. Channel B XLRs – Connects Wired Interface Port B to Port 2-Wire 2 of the Control Unit
- E. Channel C XLRs – Connects Wired Interface Port C to Port 2-Wire 3 of the Control Unit
- F. Channel D XLRs – Connects Wired Interface Port D to Port 2-Wire 4 of the Control Unit

Note: See the diagram on the next page for more information about these channel ports.

A/B and C/D Channel Ports

There are six (6) access ports for channels A/B and C/D on the front of the WI. These ports are for connecting Wired BeltPacks via a Cat 5 (RJ-45) connection. When connected to these ports, Wired BeltPack can communicate with any wireless user subscribed to the same channel (also referred to as a conference within X-Ware).

The WI is connected to the Control Unit within the 2RU press box case via four short XLR cables. Figure 13 below shows a diagram of this connection.

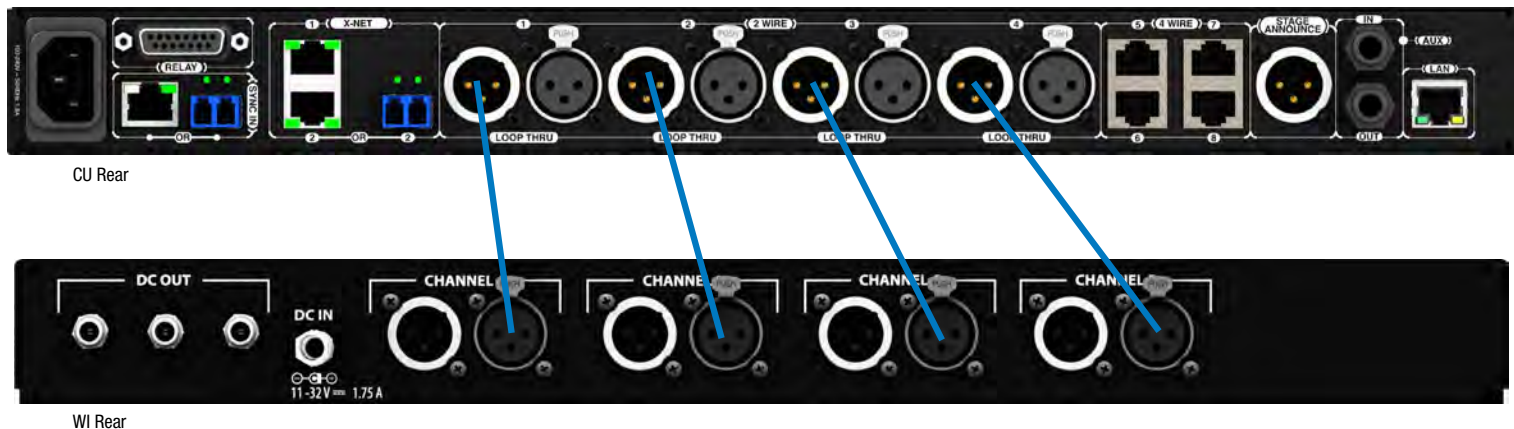

Figure 13: Control Unit and Wired Interface Connection

Default Conferences

An X-System conference is a conversation between a set group of coaches. By default, each X-System will include four conferences. These four conferences are the only ones accessible to coaches using Wired BeltPacks in the booth. If you wish to reorder these conference assignments, see “Changing Conference Port Assignments” on page 34.

Table 1: Default Conferences		
Wired Port	X-System Default	Short Name
A	Primary Offense	Pri O
B	Secondary Offense	Sec O
C	Primary Defense	Pri DEF
D	Secondary Defense	Sec DEF

Wired Interface (WI) Power

There is no power switch on the WI. The power to the WI comes on when it is plugged into an AC wall outlet. The green “Power” LED on the front of the WI indicates whether power is on or off. The AC power goes through a DC power supply and then into the “DC IN” of the WI.



Figure 14: Wired Interface Power LED

Control Unit (XCU-44)

The X-System Control Unit (CU) is located in the main rack unit in the press box. It serves as the foundation of the wireless communication system. The CU contains no radio and is frequency agnostic, which sets the groundwork for a multi-frequency capable system. For maximum flexibility, any CU can access, control, and monitor any active device across X-Net.

The X-System Control Unit is the foundation for X-Net. A separate Radio Transceiver (RT) is required for RF communications. The Control Unit is capable of supporting all models of X-System Radio Transceivers at the same time (900MHz or 2.4GHz).

Control Unit Front

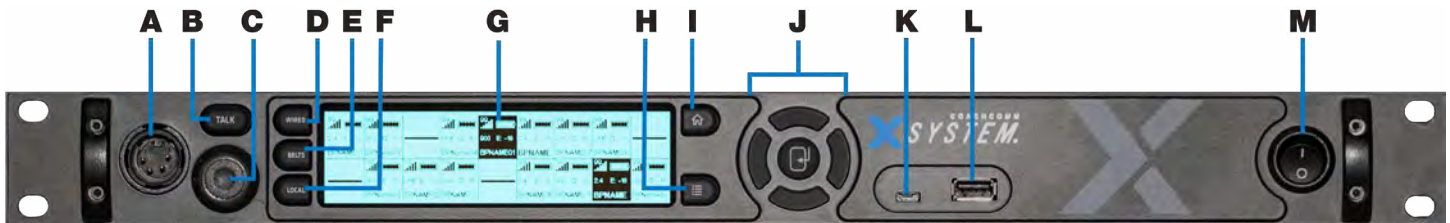

Figure 15: Control Unit Front View

- A. **Local Headset Connection** – 4-pin XLR male headset connector on the CU's front panel.
- B. **Talk Button for Local Headset** – The Talk button works in conjunction with the Local Headset Connection. The Talk button enables or disables the microphone for the local headset. A white “TALK” LED will illuminate when the mic is enabled.
- C. **Headset Volume Knob** – Turning the Volume control adjusts the listening volume of the local headset. Clockwise increases the audio level; Counterclockwise decreases the audio level.
- D. **Wired Intercom Access Button** – When pressed, the Control Unit menu jumps directly to the Wired Settings screen.
- E. **Radio Packs Button** – Switches the Home screen to a selectable mode that allows selection of a (wireless) Radio Pack to edit its settings (via the navigational controls).
- F. **Local Button** – Opens the local headset settings on top of the current screen display, allowing for adjustments to the local headset settings.
- G. **LCD Screen** – Display for viewing real-time status of system, navigating menus, and making subsequent setting adjustments. The LCD screen is the focal point of the Control Unit's functionality. On the Home screen, the LCD displays the status of all Normal mode wireless Radio Packs that are currently paired to the Control Unit. In the Menu, the LCD shows the menu items or information.
- H. **Menu Button** – Accesses the main menu system of the CU. The default pass code to access the CU menu is “0000.” While in the menu system, one short press acts as “Escape” to return to the previous menu without saving any changes.
- I. **Home Button** – Returns to the Home view when pressed. This also serves as an escape button. (Changes that may have been in process are not saved if Home is pressed before save is complete.)
- J. **Navigational Controls** – Up, Down, Left, and Right move the cursor or marker on the LCD to make adjustments in edit mode. Enter (Center) selects the current cursor position or saves the current setting adjustment.
- K. **USB Micro B** – For connectivity to a computer when performing device firmware updates.
- L. **USB A** – For Radio Pack pairing, additional X-System device connectivity to update firmware, and external USB flash drives.
- M. **On/Off Switch** – Turns the power to the Control Unit on and off.

Control Unit Rear

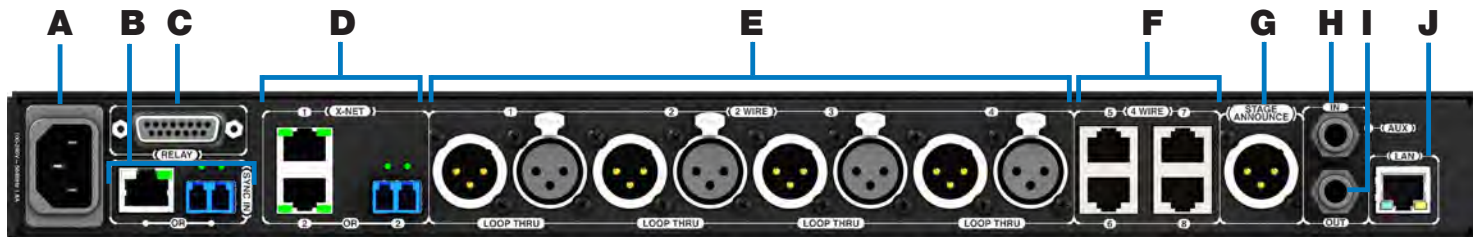

Figure 16: XCU-44 Rear View

- A. **AC Power Connection** – 100–240V, 50/60 Hz 0.8A
- B. **SYNC IN Port (RJ-45 or Fiber)** – SYNC IN allows the Control Unit to sync its timing with another external system to optimize both systems’ performance, while keeping each system’s audio separate and secure.
- C. **RELAY Connection** – Not currently used with X-System operation
- D. **X-NET Ports (Cat 5e or Fiber):** The Control Unit’s X-Net ports allow it to connect to any available X-Net port on other devices, such as RTs, forming a proprietary network where all devices are part of a system configuration that shares data, timing synchronization, and audio. Each Control Unit has up to two X-Net connections, using either two RJ-45 ports (copper that is Cat 5e or greater) or one RJ-45 port and one duplex LC port (Single Mode Fiber).
- E. **2 WIRE Intercom Port (x 4)** –The Intercom conference ports (1, 2, 3, and 4) connect the Control Unit to channels A/B and C/D of the Wired Interface.
- F. **4 WIRE Intercom Port (x 4)** – Not currently used with X-System operation
- G. **STAGE ANNOUNCE (SA)** – Not currently used with X-System operation
- H. **Auxiliary Audio Input (AUX IN)** – Not currently used with X-System operation
- I. **Auxiliary Audio Output (AUX OUT)** – AUX OUT is used to supply intercom audio sources from the X-System Control Unit, used when recording audio out of X-System. The AUX OUT connector is a ¼” Tip/Ring/Sleeve jack.
- J. **Local Area Network (LAN) Port** – The LAN port allows the Control Unit to be connected to a PC and X-Ware. See the “Connecting X-Ware to Your CU” section on page 41 of this manual for more LAN connection information.

Understanding the Control Unit's LEDs

Each LED on the rear of the Control Unit indicates a particular condition or status for the device. See the table below for details about each meaning.

Port/LED	Description	
X-Net LEDs	Left	Green – X-Net connection is good
		Off – No X-Net connection detected
	Right	On (Green) – 1000 Mbps link is detected
		Blinking (Green) – Activity is detected
LAN LEDs	Left	Green – LAN link is connected
		Off – No LAN connection detected
	Right	Blinking (Amber) – LAN activity is detected
		Off – No LAN activity detected
Sync LEDs (Copper)	Left	Green – Sync connection is good
		Red – Sync connection has a problem (e.g., when an X-Net connection is made to the sync port of a non-primary CU).
		Off – No Sync connection detected
	Right	On (Green) – 1000 Mbps link is detected
Off – No Sync connection detected		
Sync LEDs (Fiber)	Left	Not used
	Right	Green – Sync connection is good
		Off – No Sync connection detected

Note: The left LED on the Sync In copper connection will be lit on the Primary CU only. All other non-primary CU Sync In LEDs will not be lit, indicating they do not accept a Sync (X-Net) Input.

Control Unit LCD

Home Operating Screen

Serves as the primary operating screen and displays the status of the Radio Packs (RPs) connected to the Control Unit.

Note: Currently, High Density-engaged RPs do not show on the front panel of any CUs. These packs can be seen in X-Ware.

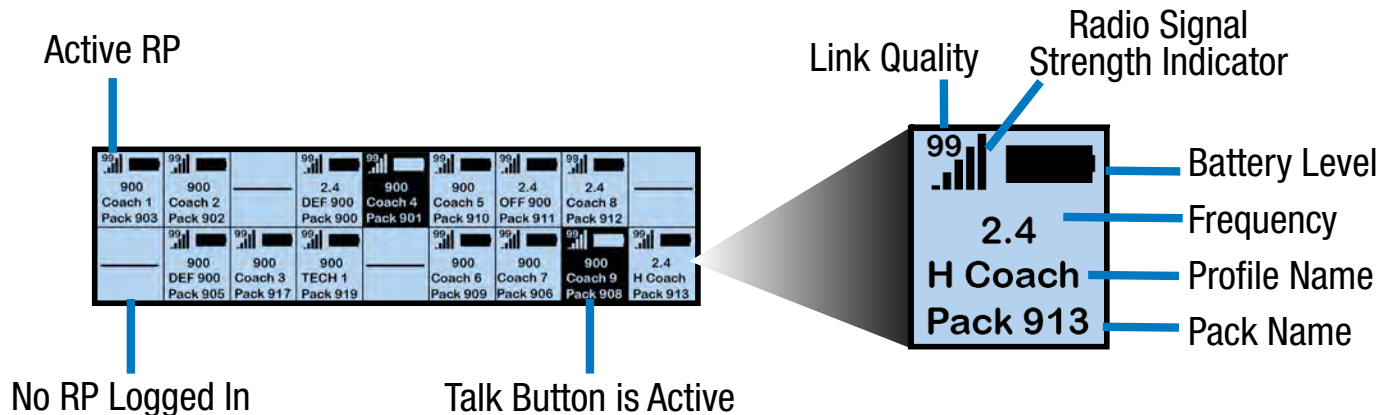

Figure 17: Control Unit Primary Operating Screen

Note: The Link Quality Indicator (LQ) provides a diagnostic measurement of actual packet transmission from RP to Antenna and vice versa. The LQ value on the Control Unit LCD represents the lowest LQ value of the two possibilities. To discover more about which value is displaying on your device, you would need to consult the individual Radio Pack or X-Ware, if being used. (See “Understanding Link Quality” on page 35 of this manual for more information.)

Secondary Operating Screen

Displays additional information about the status of the Radio Packs connected to the Control Unit. Short press the Home button once to toggle between the Primary and Secondary screens. After 60 seconds, the screen will time out and revert back to the Home screen.

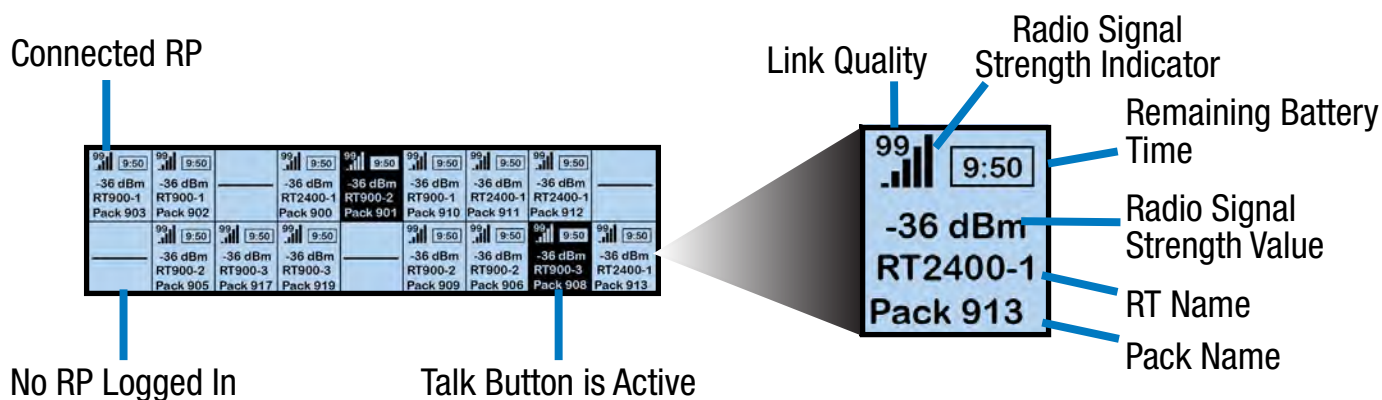
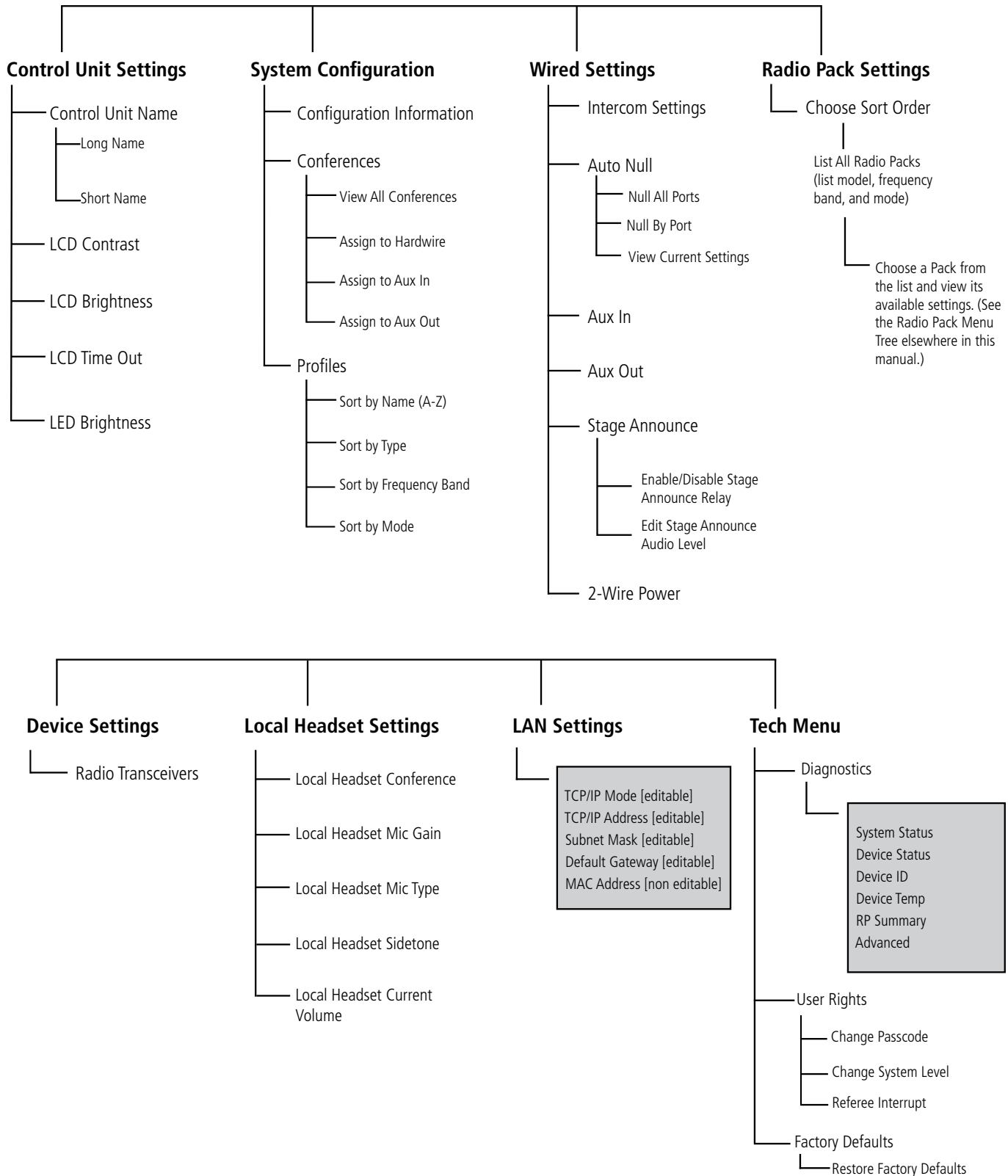

Figure 18: Control Unit Secondary Operating Screen

Note: Radio Signal Strength Value displays the actual value of the radio signal in dBm.

Control Unit Menu

The Control Unit settings can be accessed and adjusted from the Control Unit's front panel LCD, or, if being used, via the X-Ware interface on your personal PC. The following menu tree displays the Control Unit's menu options and settings.



Radio Transceiver (XRT-900 and XRT-2400)

The X-System Radio Transceiver (RT) serves as a point of contact for wireless Radio Packs on X-Net and houses either a 900MHz or 2.4GHz radio. RTs should be positioned as high as possible to provide better and more expanded coverage. (See “Mounting RTs” on page 31 for more information about positioning RTs.)

For a single Control Unit to allow the maximum 18 Normal mode Radio Packs to communicate wirelessly (6 per RT), a minimum of 3 RTs is required.

RT Top

- A. **Antenna Connections:**
RP-TNC (Connector). Only CoachComm-approved antennas may be used with X-System RTs. For more information about antenna deployment see “Mounting RTs” on page 31.
- B. **PING LED:** Not currently used with X-System.

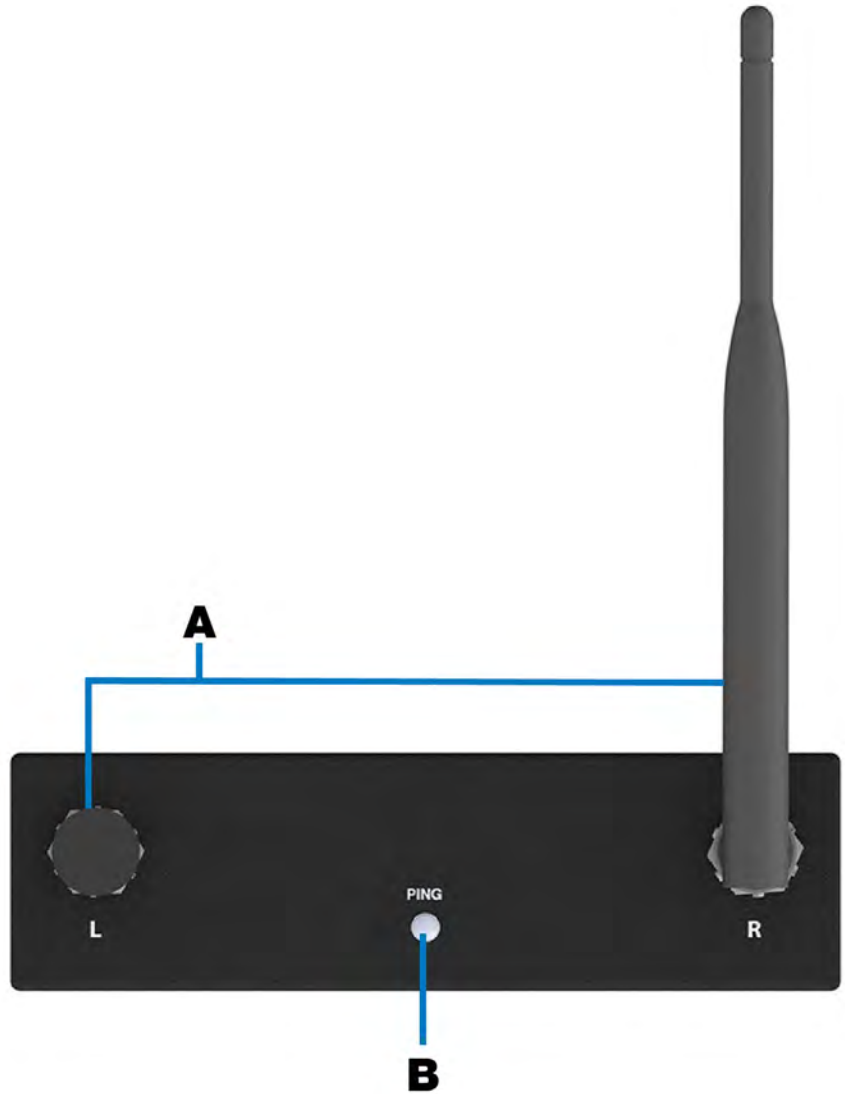

Figure 19: Radio Transceiver Top View

RT Bottom

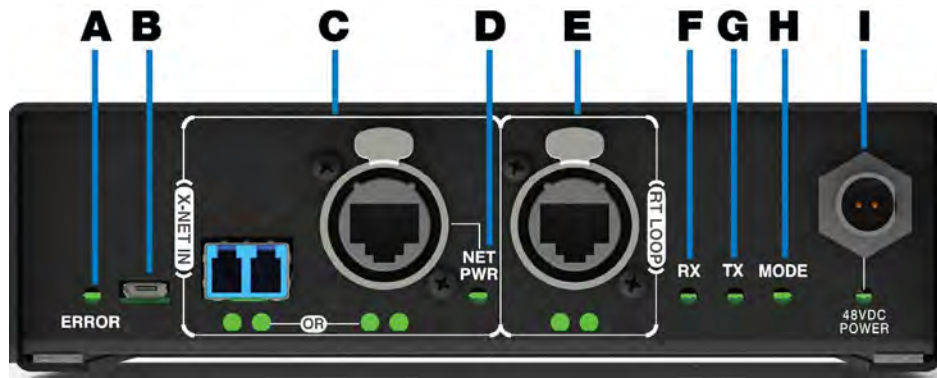

Figure 20: Radio Transceiver Bottom View

- A. **ERROR LED** – Indicates the device's error status.
- B. **USB Micro B Connection** – For connectivity to a PC when performing device firmware updates.
- C. **X-NET IN Port (RJ-45) and Status LEDs** – The RT's X-NET IN port allow it to connect to any available X-Net port or RT LOOP port on other devices, adding the RT to a proprietary network where all devices are part of a system configuration that shares data, timing synchronization, and audio. Each RT has an X-NET IN port (RJ-45) and an RT LOOP port (RJ-45, which allows RTs to be daisy-chained to one another).
- D. **Network Power (NET PWR) LED:** Indicates the presence and condition of network power, which is being provided to the unit via the X-NET IN port.
- E. **RT LOOP Port and Status LEDs:** The RT LOOP port allows you to connect multiple RTs together in a “daisy chain.” This port's status LEDs indicate the status of the X-Net link.
- F. **RX LED:** Green LED—BLINKS when RT is receiving transmissions from Radio Packs.
- G. **TX LED:** Green LED—ON (blinking rapidly) when RT is transmitting properly.
- H. **MODE LED:** Green LED—ON when set to Normal Mode; Blue when set to High Density Mode.
- I. **48VDC POWER Connection and LED:** The locking DC Power Connector enables the RT to be powered locally with a CoachComm 48VDC power supply (sold separately). Not currently used with X-System.

Wired BeltPacks (X-WBP2-01)

The X-System Wired BeltPack is to be used in the press box, connecting to the Wired Interface.

A. **On/Off/Volume Control** – The On/Off/Volume Control knob on top of the Wired BeltPack serves two main functions. First, it is the On/Off switch for the BeltPack. To turn on the BeltPack, turn the knob clockwise and watch for the LEDs on the front to come on. To turn the BeltPack off, turn the knob in a counterclockwise direction until you feel a click. All of the lights on the BeltPack should go off and you should not hear any audio in the headset. The control knob also allows you to adjust the audio level in your headset.

B. **Channel 1 and 2 LEDs (Blue)**

C. **Talk LED (Green)**

D. **Channel 1 Button** – The Channel Buttons set the BeltPack to that communication channel (indicated with blue “1” or “2” LEDs above each button). Channel “1” on the Wired BeltPack will correspond to either channel “A” or “C” of the Wired Interface, depending on where the unit is connected. The Wired BeltPack’s channel-lock feature allows coaches to be locked on a single channel, as opposed to having access to both channels. To enable this feature, hold down the channel button you want to lock while powering on the BeltPack.

E. **Channel 2 Button** – The Channel Buttons set the BeltPack to that communication channel (indicated with blue “1” or “2” LEDs above each button). Channel “2” of the Wired BeltPack will correspond to either channel “B” or “D.” The Wired BeltPack now offers a channel-lock feature that allows coaches to be locked on a single channel as opposed to having access to both channels.

Note: Only coaches who are on the same communication channel (A/B/C/D) will be able to hear each other. For more information about the conferences (channels) accessible to coaches with Wired BeltPacks see page 13.

F. **TALK Button** – The TALK button toggles the microphone of the headset on or off. The Talk LED, which is located directly above the TALK button, will light green whenever the microphone is on. When the Talk LED is on, anything you say into the headset microphone will be communicated to all other coaches on the system that are on the same channel to which your BeltPack is set. You can push the TALK Button to turn on the Talk LED and forget it, or you can use it as a momentary mute function to have off-line conversations during the game.

G. **Headset Connector (Bottom)** – The headset is connected to your Wired BeltPack via the 4-pin XLR connector on the bottom of the BeltPack. Push the headset connector all the way into the bottom of the BeltPack until you hear a click. Do not force the connector. The audio level will vary depending on the type of headset used.

H. **Wired BeltPack RJ-45 Connector (Bottom)**

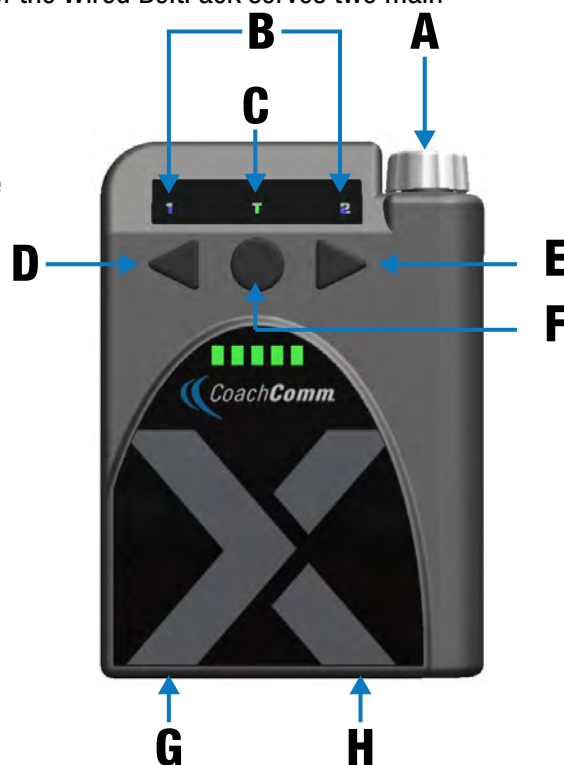

Figure 21: X-WBP2-01 Wired BeltPack

Radio Packs (XRP-13, XRP-22, and XRP-44)

The X-System Radio Pack (RP) is to be worn by a user on the sideline. This Radio Pack communicates directly to its corresponding RT. All wireless users are connected together through the wired system via the Control Unit and the WI.

The X-System RP can be used with X-System in highly-varying applications and environments.



Figure 22: XRP-13

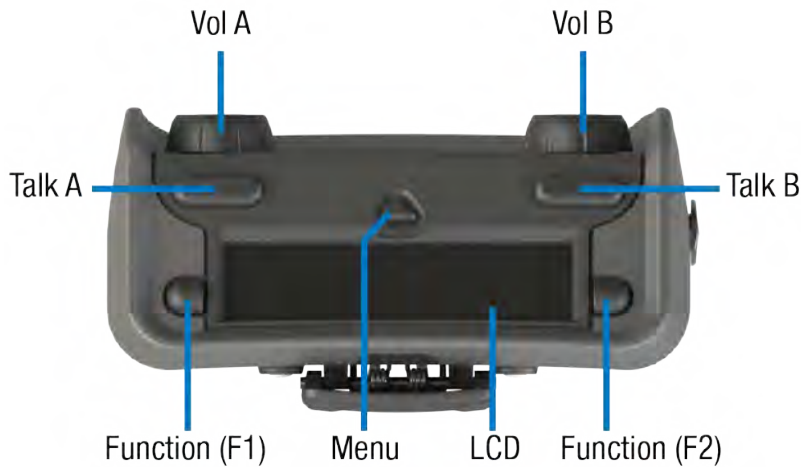

Figure 23: XRP-22

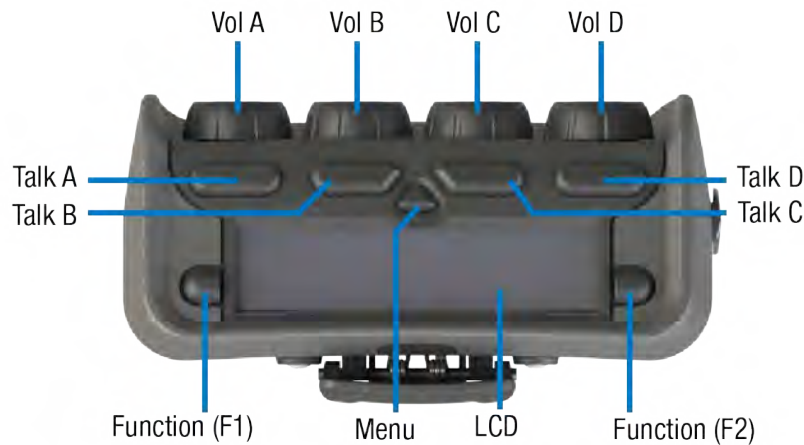

Figure 24: XRP-44

Radio Pack Top (All)

- **LCD:** Display for viewing real-time status of the RP, navigating menu options, and making subsequent setting adjustments.
- **Menu Button:** The Menu button provides multiple functions such as access to menu options or toggling between the home operating screen and the secondary operating screen.
 - » Short Press – Cycles the RP LCD from the Home Operating screen to the Secondary Operating screen and vice versa.
 - » Long Press – Accesses the menu options of the RP to view device/system information and make setting adjustments.
 - » Escape – While in the menu, one short press returns you to the previous menu without saving any changes.
- **Talk Button:** The Talk button enables or disables the microphone for the selected conference. Talk buttons can be set to function as “Latch” press, “Momentary” press, or “Always On.” In addition, X-System uses an intelligent latching method for Talk buttons. When set to “Latch,” one short press will latch the Talk on; however, pressing and holding the Talk button will cause the button to act as a momentary switch.
- **Function Buttons (F1/F2):** The left (F1) and right (F2) function buttons can be programmed to assign a variety of functions. Each Function button’s operation is set in the RP’s profile, which can be customized via X-Ware. While in the menu, one short press of F1 returns you to the previous menu without saving any changes.

Radio Pack Top (XRP-13 Only)

- **Conference A/B Rocker Knob:** The Conference A/B knob selects whether you are listening and talking to your RP Profile’s assigned Conference A or Conference B.
- **Conference C Button:** The Conference C button enables or disables the audio for the RP Profile’s assigned Conference C.
- **Volume Knob:** The Volume control adjusts the listening volume of the connected headset for the selected conference. Turning the Volume control clockwise increases the audio level, while turning the control counter-clockwise decreases the level.
 - » This control also serves as an Audio Overlay (AO) volume control when pressed and turned simultaneously. (AO must be enabled on Conference C first. See page 60 for more information about setting up AO.)

Radio Pack Top (XRP-22 and XRP-44 Only)

- **Volume Knobs:** Two volume knobs are available on the XRP-22 Radio Pack and four are available on XRP-44, and they are named from A to B and A to D, respectively, from left to right in X-Ware.

Radio Pack Rear

- **Belt Clip:** Secure and sturdy belt clip enables Radio Pack wearing via belt.
- **Battery Compartment Door:** Secures and protects the Radio Pack's Lithium-Polymer battery or 3 AA batteries.
- **Battery Door Latch/Magnet:** Secures the Radio Pack's battery door.
- **USB (Micro B) Connection:** This USB connection is for connecting a Radio Pack to a Control Unit for pairing and firmware updates. The Radio Pack may also be connected to a PC for firmware updates via X-Ware. See page 69 for more information on updating firmware.
- **On/Off Button:** The On/Off button powers the Radio Pack on and off when pressed for 3 seconds.
- **4-Pin Male XLR Headset Connector:** Headset connector is a 4-PIN male XLR connection. Optional XLR adapters (4-PIN female to 4-PIN female and 4-PIN female to 5-PIN female) are sold separately.

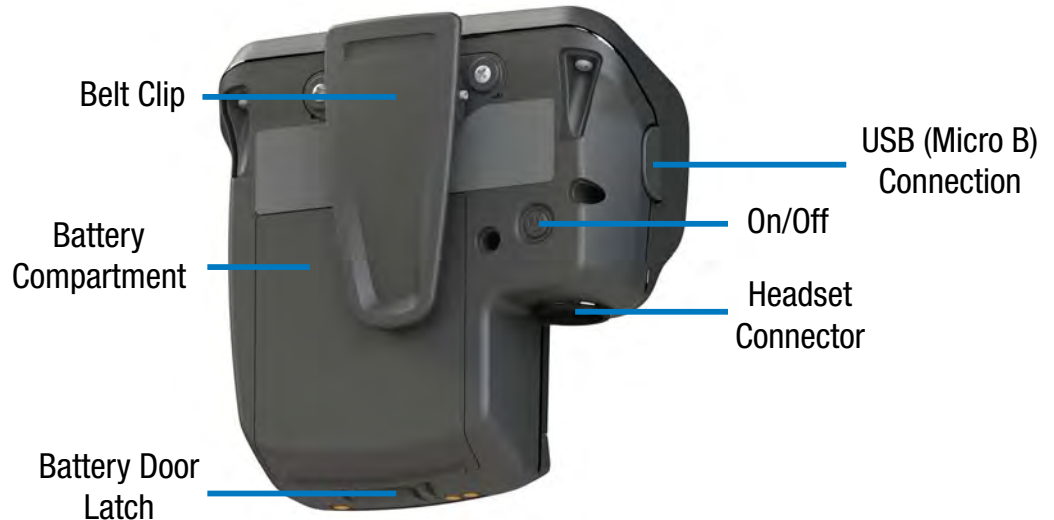

Figure 25: Radio Pack Rear View

Radio Pack LCD

Home Operating Screen

Serves as the main operating screen and displays the status of the Radio Pack as well as talk, volume, and function assignments.

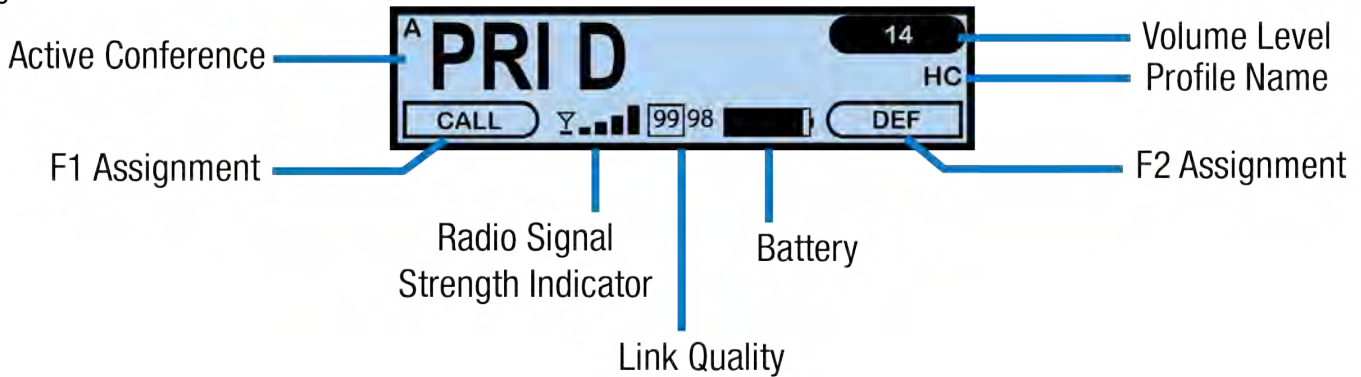

Figure 26: XRP-13 Home Operating Screen

Note: The Player Communication Mode (ISO, MIX, or SW) will replace the small A in the top left corner when the Function button is pressed on an active conference that includes X-System Players. Only XRP-13s support coach to player communications. XRP-22 and XRP-44 do not support coach to player communication using the function buttons, but the Talk buttons can be assigned to a player conference. The function button options below will not be available when the conference is assigned a Talk button.

Note: The Link Quality Indicator (LQ) provides a diagnostic measurement of actual packet transmission from Radio Pack to RT and vice versa. The outlined LQ represents the Radio Transceiver's LQ. (See "Understanding Link Quality" on page 35 of this manual for more information.)

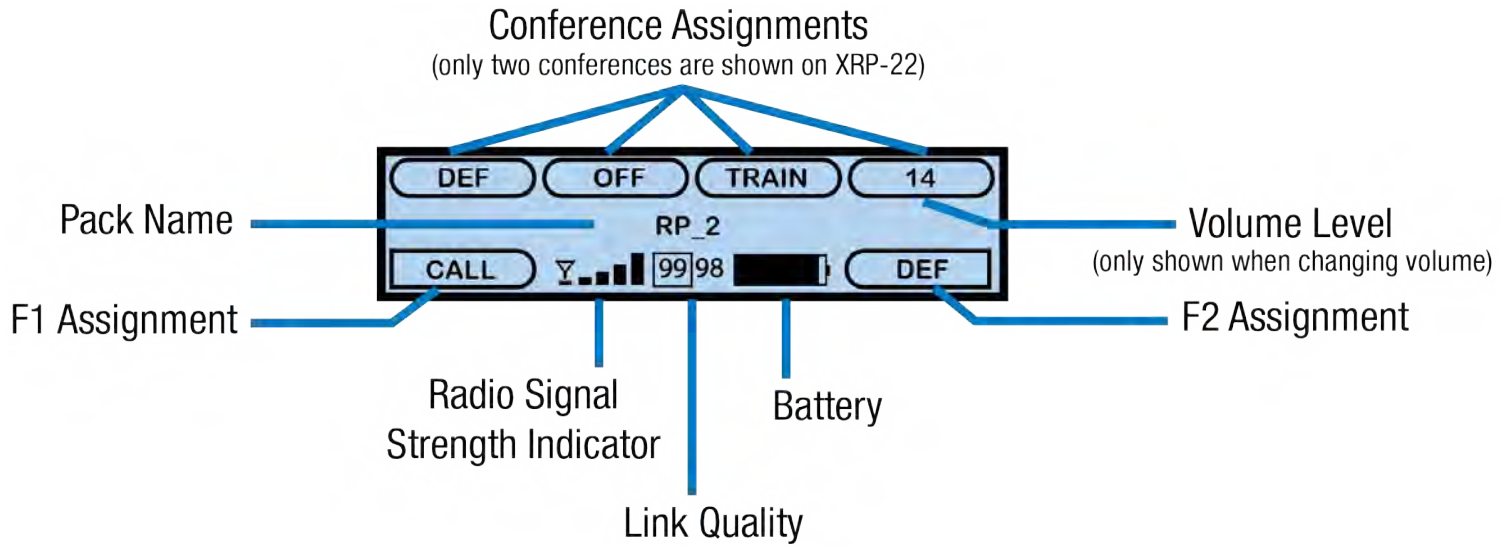

Figure 27: XRP-22 & XRP-44 Home Operating Screen

Secondary Operating Screen

Serves as a secondary operating screen and displays additional information about the status of the Radio Pack. Short press the Menu button once to toggle between the Home and Secondary screens. After 60 seconds, the screen will timeout and revert back to the Home screen.

Note: Radio Signal Strength Value displays the actual value of the radio signal in dBm.

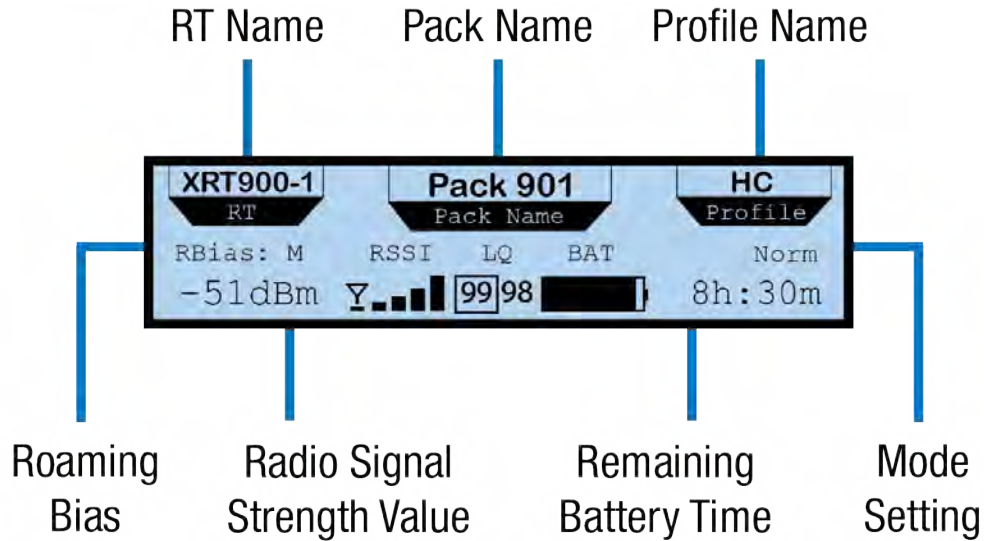
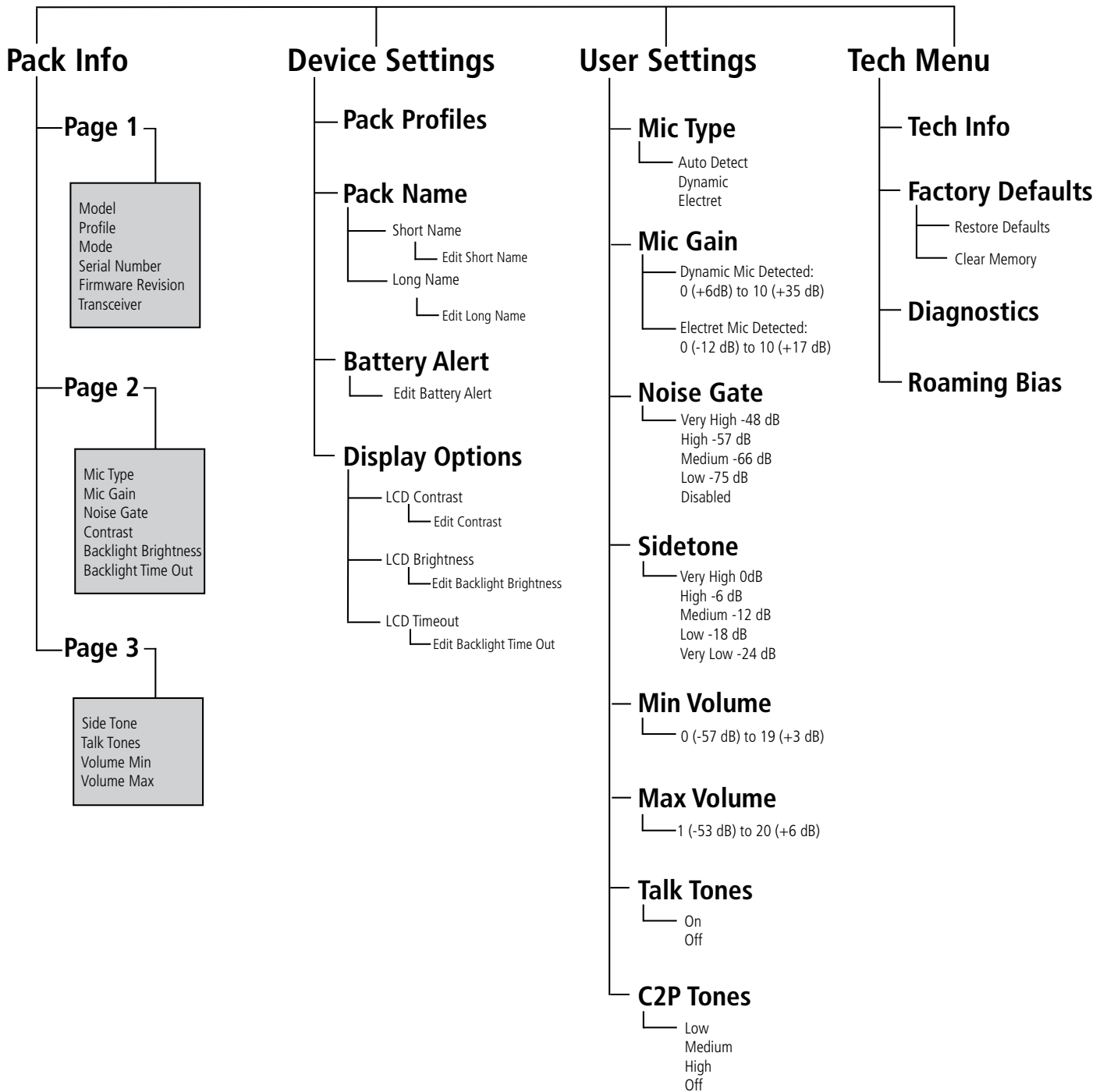

Figure 28: XRP Secondary Operating Screen

Radio Pack Menu

Radio Pack settings can be accessed and adjusted from the Radio Pack's LCD, the Control Unit's LCD, or via the X-Ware interface on the touch screen monitor. The following menu tree displays all of the Radio Pack's menu options and settings:



Radio Pack Battery System

Radio Packs (RPs) are powered with one (1) Lithium-Polymer rechargeable battery for greater than 9 hours, or they may be powered with three (3) AA Alkaline batteries for approximately 4.5 hours (900MHz).

There are several considerations you should take into account when using AA batteries. The RP's battery level and remaining battery time indicators only reflect battery life for lithium-polymer batteries; therefore, those screen options will not be used when AA batteries are in use. In cold weather, AA batteries do not release their stored energy completely, so the result is a dramatic reduction in operation time. It would not be uncommon to have an AA battery only last 50% of its original life when used in very cold situations. Also, remove the AA batteries when not in use to avoid potential damage from leaking battery acid that can sometimes occur in these type batteries.

The battery can be charged in multiple ways.

Charge via RP Wall Charger

To charge the RP, connect the plug-in battery charger to a standard wall outlet and to the Micro-USB connector on the RP. The connector is located under the rubberized access cover on the side of the RP. The battery requires approximately three (3) hours to charge from empty.

Charge via USB Cable

The RP may also be charged by connecting the USB-A-to-Micro-B pairing cable to the USB port of a PC and to the Micro-USB connector on the RP. The connector is located under the rubberized access cover on the side of the RP. The battery requires approximately three (3) hours to charge from empty.

Charge via 5-Bay Battery Charger

The CoachComm 5-Bay Battery Charger charges up to five (5) CoachComm lithium-polymer batteries at the same time. The battery requires approximately 3 hours to charge from empty.

The charger should be used in a cooler area to prevent overheating. As a lithium-polymer battery safety mechanism, the battery charger includes a safety circuit, which prevents charging of batteries if the ambient temperature is too hot.

Charge via 6+6 Drop-In RP and Battery Charger

The CoachComm 6+6 Drop-In RP and Battery Charger charges up to six (6) batteries in the Radio Packs and up to six (6) stand-alone batteries. Batteries inside RPs require approximately 4 hours to charge from empty; batteries alone require approximately 2.5 hours to charge from empty.

The charger should be used in a cooler area to prevent overheating. As a lithium-polymer battery safety mechanism, the chargers will disable charging if batteries are too hot (over 113°F).

Installing a Radio Pack Battery

Before powering on an RP, install its battery by doing the following:

1. Hold the RP at a 45-degree angle, pointing the bottom end down. Then, depress and hold the RP's belt clip down.
2. Lift open the battery door and remove it.
3. While still holding the RP at a 45-degree angle and depressing the belt clip, install a fully charged Lithium-Polymer rechargeable battery or three AA batteries in the RP. Take care to insert the battery with the contacts facing down into the RP and oriented such that the contacts on the battery will line up with the contacts inside the RP battery compartment.

4. Place the battery door back on the RP, making sure to align and insert its tab at the top first, and then secure the door by pressing until it clicks. (Secure a magnetic door by pressing firmly until the magnet engages.)
5. Turn on the RP by pressing and holding the Power button on the back of the pack for 3 seconds.



Figure 29: Rear View of RP's Power Button and Battery Door



Figure 30: Radio Pack Battery Installation

Note: The RP will not operate unless it has been paired to a Control Unit; if it has not been paired it will indicate “No Pairing Information Available” on the pack’s display. In addition, the RP will not communicate if its CU And RTs are not yet online. CoachComm recommends powering on the CUs and RTs first before powering on the RPs.

Pairing an RP to a Control Unit

RPs must be paired to a Control Unit (CU) before they can operate with your X-System. Once RPs are paired to a CU, this process does not need to be done again unless the RP is being paired to a new or different CU (for example, after a replacement is made for repairs). An RP may be paired without installing a battery, if required. In this case, the CU will provide power to the RP during the pairing process. If no battery is installed, the RP will power down as soon as it is disconnected from the CU.

- **Compatibility Note:** To work together as a system, all connected devices must have firmware that matches the version installed on the CU. See “Updating Device Firmware” on page 39 for more information.

To pair your RP, use the following steps. **IMPORTANT:** While pairing, do not disconnect the RP until you are instructed to do so.

1. Connect the Antenna(s) (on the mounting bracket) to the Press Box Rack Unit’s rear panel. Then, power on the CU.

- When prompted on the CU, select either **Home** or **Away**. Wait about 2 minutes for the configuration file to load on the system—the CU will display a “CCF Loaded” message and a configuration file summary—wait until this message has cleared from the screen before taking further action. Once the message times out, the home screen will display on the front of the CU.

CCF Loaded			
Version: 3	Flags: 02	Length: 21,232	Number of Devices: 8
Device Connection: 7	Control Unit: 2	Expansion: 0	Hub: 0
Radio Transceiver: 6	Radio Pack: 36	Radio Pack Profile: 36	
Conference: 12	Relay Assignment: 0	Aux Audio Assignment: 0	
User Info Record: 0	Access Rights: 0	UI Data: 0	

Figure 31: CCF Loaded Screen

- Ensure the RP to be paired is powered OFF.
- Connect a USB-to-Micro-USB cable from the CU to the device (micro end goes into the RP’s USB port beneath its rubber port cover). The RP will power on by itself. Pairing begins automatically and should take about 30 seconds.
- When prompted, use the RP volume knob and function buttons to choose a Profile from those available in the list on the RP’s LCD. You will need to use the RP volume knob and function buttons to make your selection.
- Wait for the profile to load. The LCD will display a “Pairing Complete” message when the profile is finished loading.
- Disconnect the USB cable from the device. The RP will power down automatically when disconnected.
- Power on the RP and wait for it to log in to the system. The initial login may take up to 90 seconds. When an RP is logged in, its RSSI indicator will display on the primary LCD screen.
- If using X-Ware, you can verify that the RP paired correctly and is displayed in X-Ware. You may need to refresh the X-Ware display by clicking on the grid button on the right-hand side of the X-Ware screen (See Figure 32).



Figure 32: X-Ware Grid Button

NOTE: If you’re using a new or recently serviced CU, or if you are pairing an RP that has never been paired to your system, the RP icon(s) in X-Ware will default to the top left corner of the software Home screen. Position the icon(s) as desired for your configuration. In order to save your custom Home screen, you will need to save your configuration file to a USB drive and reload the file to the top CU after pairings are complete. See “Saving a Configuration File” on page 65 for more information about this process.

- The RP is ready for use. Repeat steps 4–9 until every RP is paired.

View CU Pairings

The list of paired RPs can be found in the CU and in X-Ware’s Advanced Settings. In the CU menu > Radio Pack Settings, select a sort option to view the paired RPs. In X-Ware’s Advanced Setting under the Device Management tab, the paired RPs list can be found to the right of the Control Unit port information.

System Accessories

Press Box Cables

Wired users are connected to the X-System via press box cables. Press box cables are the bundled Cat 6 cables that connect the Wired BeltPacks to the Wired Interface.

Headsets

Previous models sold are the PH-100 and PH-200, the HR-1 and HR-2, and the SM-100 and SM-200. CoachComm now offers exclusively the SmartBoom[®] series of headsets (SBP-191 and SBP-192). The SmartBoom technology enables you to effortlessly mute your microphone by simply raising the boom above your brow. Re-enable the microphone by lowering back to the mouth. All headsets have a 4-pin XLR connector.



Figure 33: Dual-Ear Model SmartBoom PRO Headset



Figure 34: Single-Ear Model SmartBoom PRO Headset

System Setup and Operation

Mounting RTs

Your field RT is located in the press box case under the Press Box Rack Unit, along with its mounting hardware. You have two options when mounting your RT: using the suction cup or the super clamp. Setup instructions for each type of mount are provided below.

Important! Use only approved antennas to avoid possible FCC violations! The antenna mounted to the XRT-900 is not user replaceable.



CAUTION: Failure to comply with the following may result in equipment damage, damage to surface area, or personal injury.

Using the Suction Cup

1. Loosen the ball mount knob so the hex standoff can rotate.
2. Twist the RT's hex standoff onto the top of the suction cup's stud, securely tightening it. Then, re-tighten the ball mount knob.
3. Attach the suction cup's safety cable to a fixed object.
4. Press the suction cup to a dry, flat surface, such as a table or a glass window.

CAUTION: Attempting to secure the suction cup to a moist or textured surface may cause malfunction, which could result in damage to equipment, persons, or property below mounting area.

5. Press the pump button until the red line on its side is no longer visible.
6. Point the front of the RT toward the center of your team's coaches' box. (Loosen the ball mount knob to adjust the angle of the RT, if needed.)
7. Connect a Cat 5 cable to the X-NET IN port on the RT. Connect the other end of the Cat 5 cable to the FIELD ANTENNA port on the Press Box Rack Unit's rear panel.

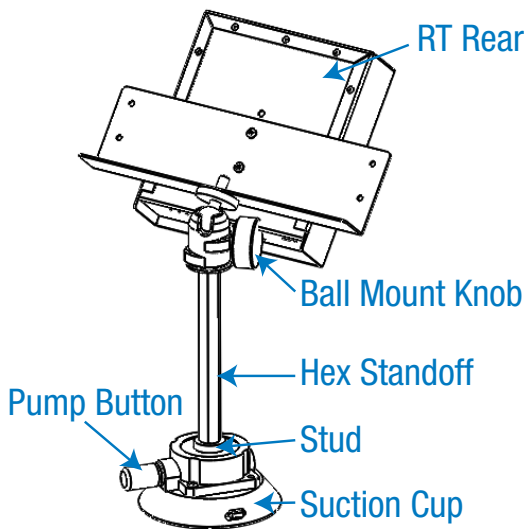

Figure 35: Single-Mounted RT with Suction Cup

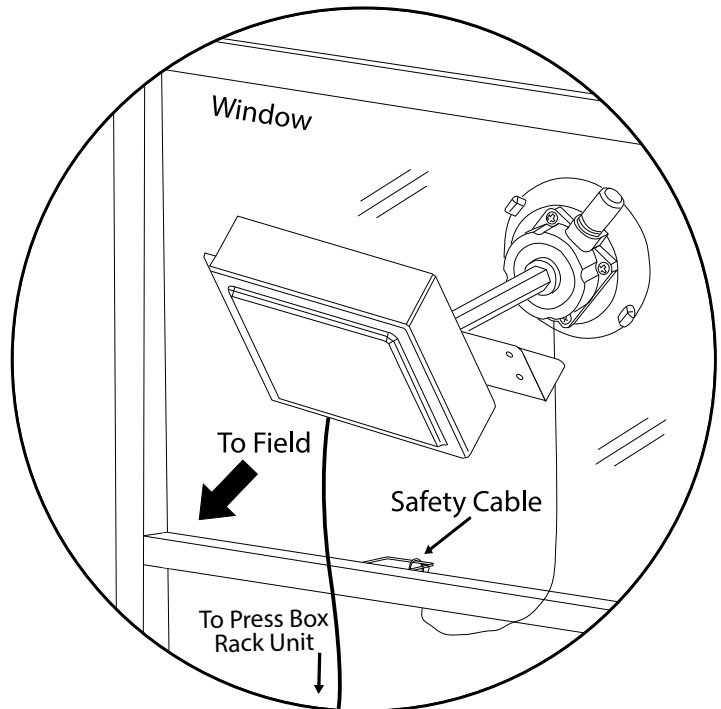

Figure 36: Window-Mounted RT

Using the Super Clamp

1. Loosen the clamp's small screw.
2. Press the clamp's side button as you insert the RT's hex standoff into the opening and tighten it. Release the button once the standoff is fully seated.
3. Tighten the clamp's small screw.
4. Fasten the clamp to the desired location, such as a railing or the side of a table, using the clamp's larger screw to loosen and tighten it.
5. Point the front of the RT toward the center of your team's coaches' box. (Loosen the ball mount knob to adjust the angle of the RT, if needed.)
6. Connect a Cat 5 cable to the X-NET IN port on the RT. Connect the other end of the Cat 5 cable to the FIELD ANTENNA(S) port on the Press Box Rack Unit's rear panel.

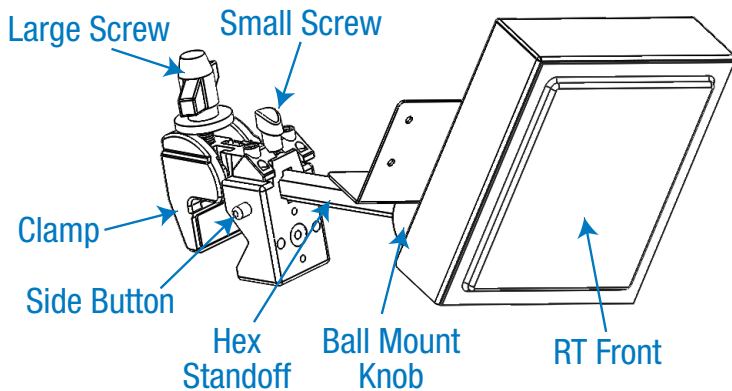

Figure 37: Single-Mounted RT with Clamp

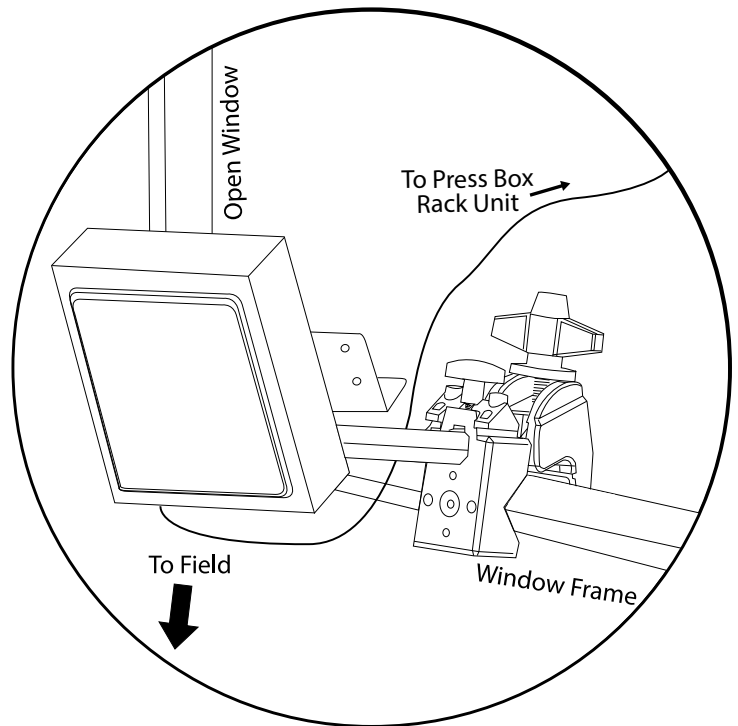

Figure 38: Clamp-Mounted RT

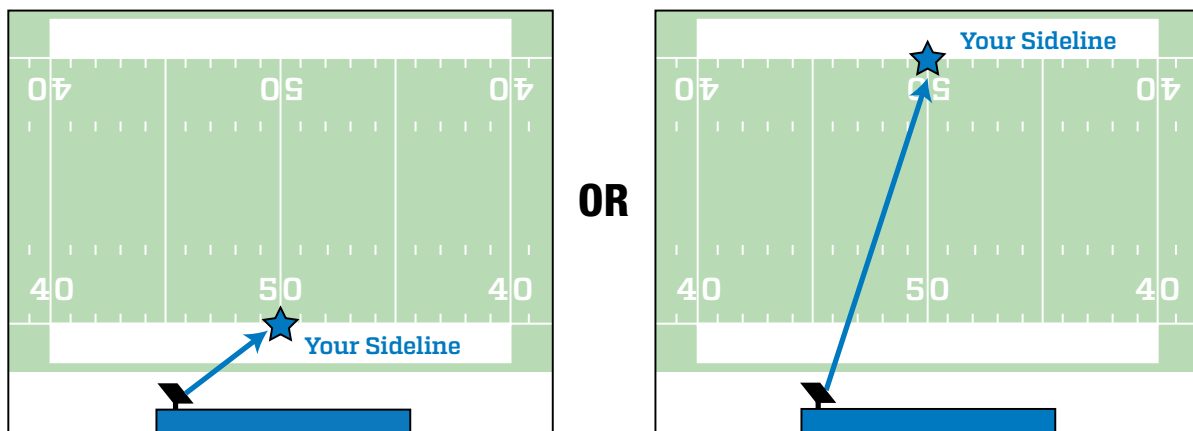

Figure 39: Center of Your Coaches' Box

Dual RT Systems

Some customers may use a dual-RT system. In that instance, two RTs are mounted together on the same bracket, and the suction cup and the super clamp function the same way as detailed on the previous pages.

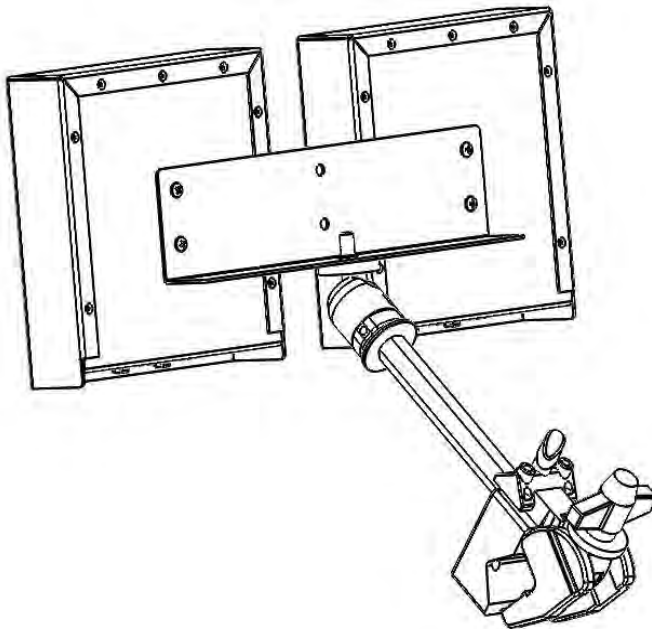

Figure 40: Dual-Mounted RT

Covering Your RTs

When using your RTs in a wet environment, protect them with a protective enclosure that will not interfere with the RF (for example, a clear plastic bag). CoachComm recommends either covering each RT individually with small bags or covering the whole bracket with a large bag. The X-System RTs are weather-resistant, including gaskets intended to prevent moisture entry from the top and sides. The cable connections on the bottom are not water tight.

Setting Home/Away Status

When you power up the X-System, a prompt for selecting “Home” or “Away” displays on the Control Unit (CU) LCD. Based on this setting, all of the RTs on the system will be assigned specific hopping patterns by the CU. A selection must be made before you can proceed with system setup.

It is very important to set this status correctly. Hopping pattern coordination prevents interference between X-Systems. Once the Home/Away prompt is cleared, the CCF load progress can be seen on the CU screen. When the CCF load is complete, a “CCF Loaded” message will display along with a system configuration file summary. Once the message times out, the home screen will display on the front of the CU and you can proceed.



Figure 41: Control Unit Home/Away Status Prompt

Changing Conference Port Assignments

You may rearrange or duplicate the conferences assigned to the Control Unit's ports (and therefore used from the Wired Interface) by changing the setting from the CU's front display, as detailed below.

1. Press the menu button on the bottom right side of the CU's LCD screen. The CU menu will display.
2. Use the CU's navigation buttons to find and select **System Configuration**, then **Conferences**, then **Assign to Hardware**.
3. Select a Control Unit port from the list and a list of available conference assignments will display.
4. Choose a new conference assignment for that port from the list.

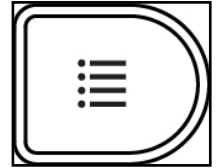

Figure 42: CU Menu Button



Figure 43: Control Unit Menu - Conference Assignment

5. Press the CU's home button to return to the Home screen.

Assign Profiles from the Control Unit

If needed, you may change a device's profile assignment from the Control Unit menu rather than from X-Ware. (For more information about how to do this via X-Ware, see page 34):

1. Press the Packs button on the front of the CU.
2. Use the CU's navigation buttons to navigate through the menu screens to **Radio Pack Settings > Sort By** _____ (where you choose the identifier to sort by).
3. Select an RP or player module from the list and navigate through the sub-menu that displays to **Device Settings > Radio Pack Profile**.
4. Select a profile from the list to assign to the selected device. The device will momentarily log out and lose communication while the profile change takes effect.

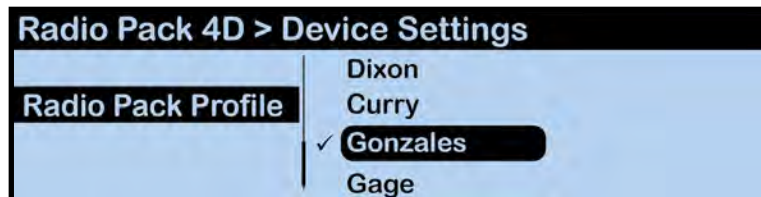

Figure 44: Control Unit Menu - Device Profile Assignment

Walk Testing Your System

Walk testing is very important. If a user only tests the Radio Packs (RPs) while standing still, he may not discover potential frequency problems. Follow the steps below to properly walk test your RPs:

1. On the sideline, unpack the sideline case and install one of the provided, fully charged Lithium-Polymer rechargeable batteries or three AA batteries in each RP.
2. Power on the first two RPs by pressing and holding the Power button on the back of each RP for 3 seconds.
3. Confirm each RP is on the same conference, connect a headset to each RP, and conduct a walk test to confirm their operation. The RP's LQ value can be used to gauge performance. See the following section for more information about LQ values.

Important: Each tester should walk their RPs to opposite goal lines and back, ensuring clear communication between all RPs. Always place the RP on the hip opposite from the press box when walk testing.

4. After walk testing is complete, mute the RP by either turning the Talk button off or raising the SmartBoom PRO mic, then place the RP down on a table or bench. Be sure to place each RP a foot or so apart; bunching RPs together could impact wireless performance.

Important: If raining, cover the RPs or return them to their cases.

5. Repeat steps 2–4 for each of the remaining RPs.
6. Confirm communication between RPs and Wired BeltPacks.

Understanding Link Quality

The Link Quality (LQ) is a numeric value that provides a real-time metric on the quality of communication between the radio in the Antenna and the radio in the RP. The LQ serves as a diagnostic tool for proper system operation and troubleshooting RPs.

- With X-System, the receiving LQ signal is reported for both the T and RP. The RP's on-screen LQ indicator with the box around it is the RT's LQ from the RP. If this LQ is lower than normal, then it is an indication that you may have an issue related to interference, the RT, or a cable connection. If only the RP's LQ is low, it could be an indication that you may have an issue related to interference or the RP.
- What should the LQ value be during operation? — There is no exact value that LQ will remain at during system operation. Depending on what degree of outside interference or attenuation (blocking) is present, the LQ will fluctuate during normal operation. Fluctuations in LQ can and will span a wide range of values. The lower the LQ, the poorer the audio quality will be during operation. During start-up, within adequate range and no outside influences present, the LQ should display “99” which is the highest LQ value a RP or Antenna can have.
- What if the LQ on a single RP is below “99” at start-up? — This depends on where the RP is located at start-up, but if the other RPs on the same Antenna are at “99” this is a good indication that isolated radio issue exists within that RP. If the LQ value has dropped considerably lower or if that unit is experiencing poor audio quality, it may require service.

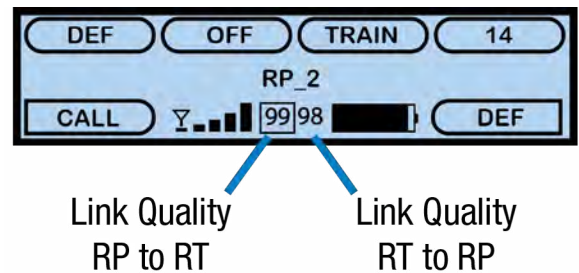

Figure 45: RP Primary Screen LQ Indicator

X-Ware Setup and Installation

X-Ware is X-System's proprietary intercom management software, and its easy-to-use game day interface provides fast access to critical information and settings, allowing efficient management of large systems. Within X-Ware, you can manage user settings, set up and manage profiles, and access system diagnostics.

X-Ware is not required for system operation; it is an optional tool to assist in real-time monitoring and changing of X-System settings. If you would like to install X-Ware on a PC to use with your system, your PC will need to meet the following system requirements:

What You Will Need

- At least one USB-A-to-Micro-B pairing cable (provided with your X-System)
- New X-Ware version (downloaded from CoachComm's website or available on the USB drive included with your X-System)
- [Optional] Downloaded and/or printed copy of this manual for easy reference during the update.
- PC that meets the following system requirements listed below

Installing and Updating X-Ware

Use the following steps to update the version of X-Ware on your sideline cart PC or to install an instance on a separate PC.

System Requirements

- Windows 7 or higher
- 4 GB system memory
- Intel Core2 Duo CPU @ 2.67 GHz or better
- 128-megabyte (MB) graphics card
- .NET version 4.8 or higher

Additional Recommendation

- XGA video screen; 1024 × 768 or greater resolution

Update Procedures

IMPORTANT: Be sure to save a copy of your current configuration file before updating X-Ware.

1. Locate X-Ware application files on PC at C:\Program Files (x86)\CoachComm\XWare #.#\.

2. Double-click the “Uninstaller” application file to open the uninstall wizard.

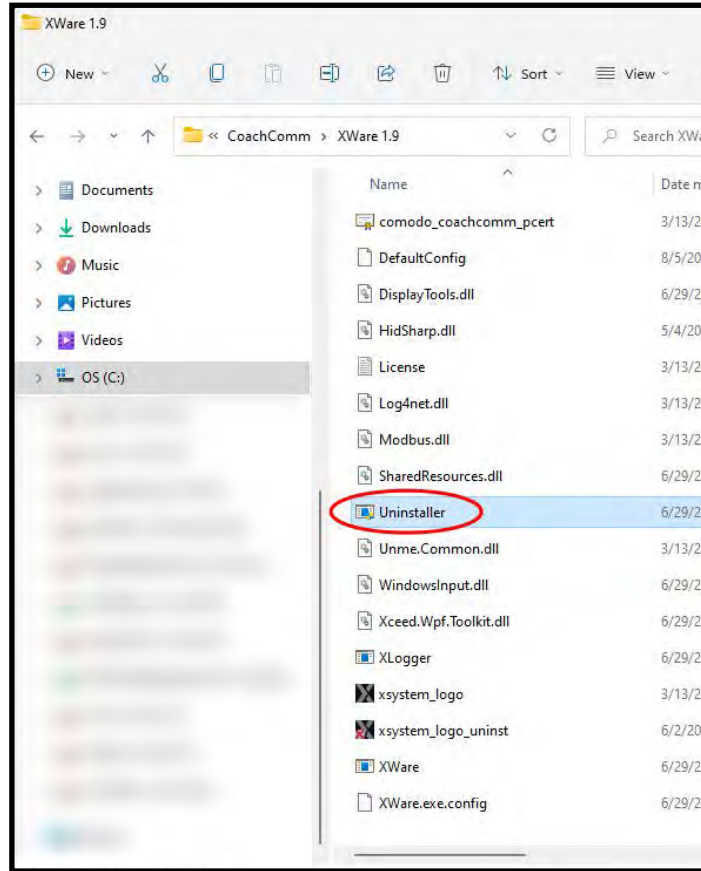

Figure 46: X-Ware Uninstall Application File

Note: You may need to make an exception for the uninstaller program in your PC’s anti-virus or security program for it to run.

3. Click **Uninstall** to begin process.

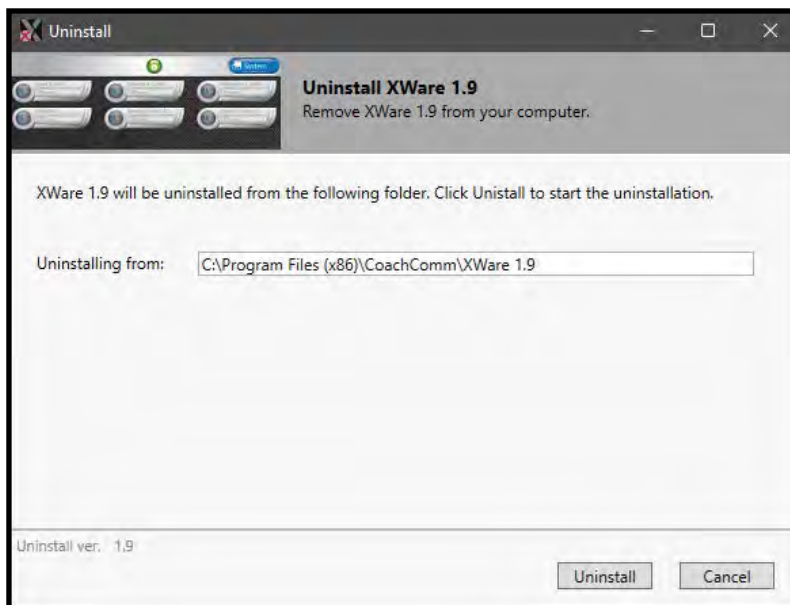

Figure 47: Uninstall Process Screen

- You will be asked to confirm your decision to “Delete all user files.” Click **Yes**.

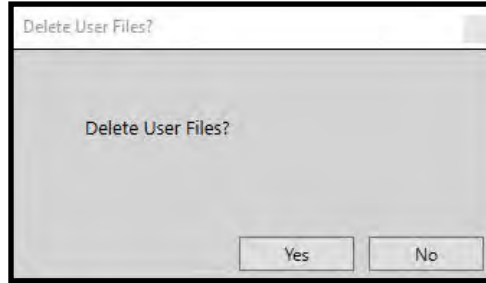

Figure 48: Confirm X-Ware Uninstall Screen

- The uninstall process will complete. Click **Close**. Verify the original X-Ware folder is now empty. If not, delete any remaining files.
- Reboot/restart the PC.

Once you’ve uninstalled X-Ware from the cart computer, use the following steps to install an updated version of X-Ware.

- Download a copy of the latest X-Ware update from the CoachComm website. (You should receive a link to the exact location in the release announcement).
- Once it is downloaded (likely to your PC’s “Downloads” folder), save the “XWare_Setup_v#. #” file to a removable USB drive.
- Insert your removable USB drive to your cart’s PC, and double-click on the “XWare_Setup_v#. #” file to run it on the cart PC. An X-Ware installation prompt window will open.
- On the License Agreement screen, click **I Agree**.

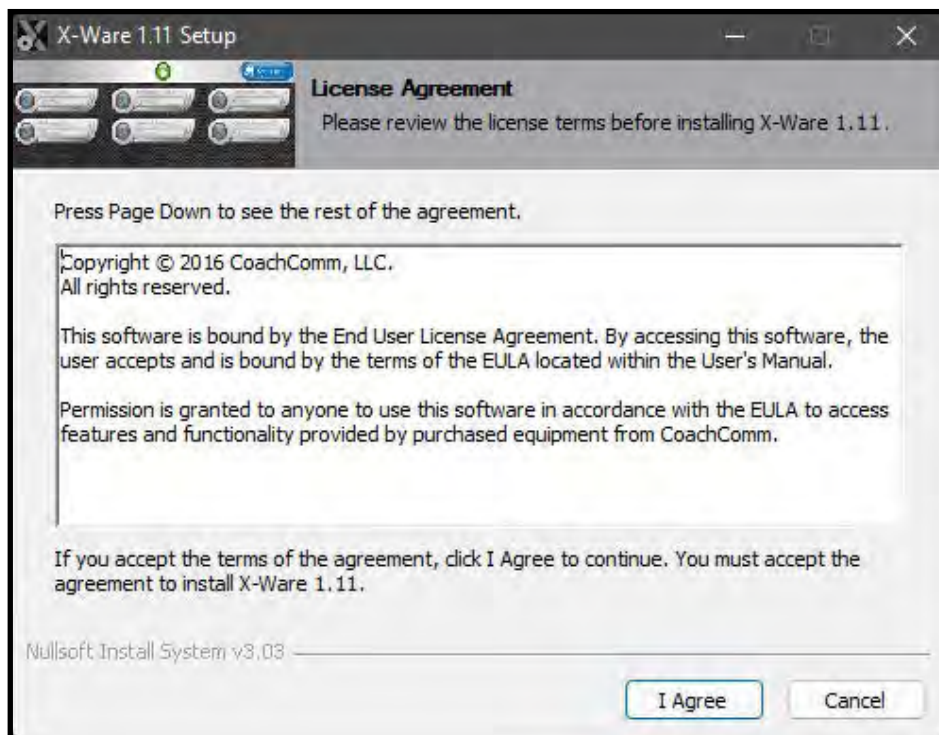

Figure 49: License Agreement Screen

- On the “Install Location” screen, click **Next** to install X-Ware into the default destination folder.

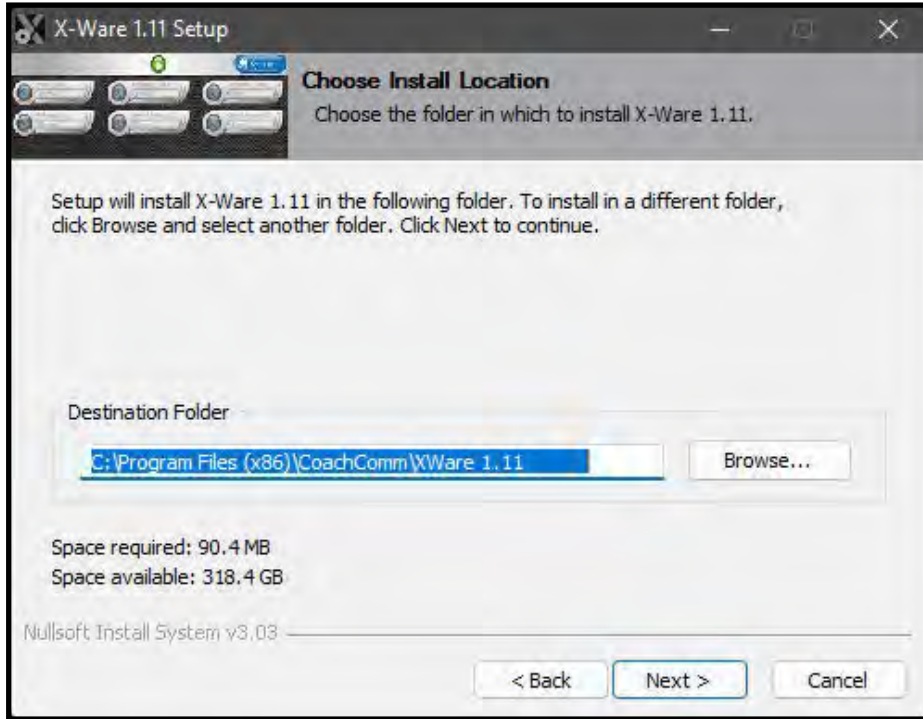

Figure 50: Default X-Ware Destination

- On the “Start Menu Folder” screen, click **Install** to begin install. Installation process will begin and take only a few seconds. Click **Close** when complete.
- An X-Ware icon should have been placed onto the desktop and is ready for use.

Updating Device Firmware

The current firmware package requires connecting devices directly to the PC USB for firmware updates. Update times may vary by device. You may also review our [“How to Update X-System Device Firmware \(X2\)” video](#) for supplemental update instructions.

IMPORTANT: Always update the top (ontrol Unit (CUs) first, followed by your bottom (secondary) CU if applicable, then your Antennas (Radio Transceivers or “RTs”), and then your Radio Packs (RPs).

IMPORTANT: When updating each CU’s firmware to version 1.9, an additional file upload directly to the CU (via front panel USB) will be required. Upon clicking “Scan for Devices” in X-Ware’s firmware tab, you will find step-by-step instructions for this process.

IMPORTANT: Always follow any specific firmware update instructions delivered with the new release. Firmware release notes and any separately published update procedures supersede the information provided below.

Prerequisites:

- Make sure that you have connected X-Ware to your CU using steps 1–6 of “Connecting X-Ware to Your CU” on page 41.
- Make sure that you have saved a backup copy of your CCF and that the most recent version of X-Ware is installed on the PC. See page 69 for more information about how to update X-Ware.

Firmware Update Procedures:

- Connect the RTs to the press box unit.

- Power on the Control Unit, select **Home** or **Away** from the CU's LCD, and wait for the configuration (CCF) to load. The empty Home screen will display on the CU's LCD. The RTs' LEDs will light to indicate that they are receiving power.

Note: If your system includes a spare RT, you can update it after the rest of the system is updated by connecting it in place of one of the other RTs. You may leave your RTs on the mounting bracket for their firmware update.

- Verify that all RPs are powered off and close X-Ware if it is currently open.
- On your PC, hold down the CTRL key and double-click the X-Ware desktop icon. Continue holding down the CTRL key until X-Ware's Advanced Settings window opens.
- Click on the "Firmware" tab. Then, click the "USB Devices" sub-tab.
- Connect a USB-to-Micro-USB cable from the PC to the CU (micro end goes into X-Device).

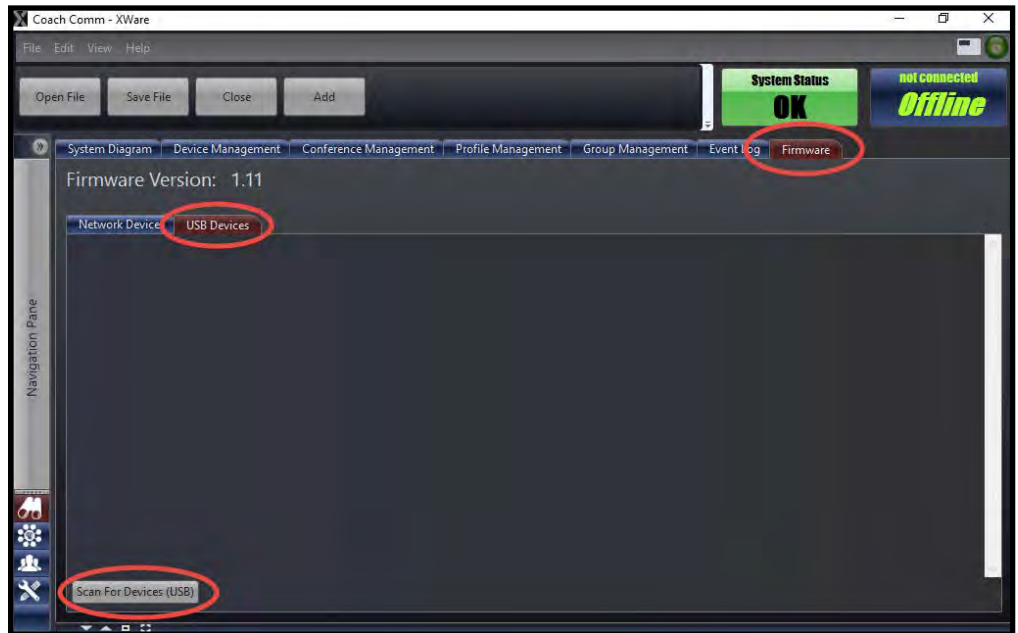

Figure 51: X-Ware Firmware Tab

NOTE: CoachComm recommends updating the CU and RTs one device at a time; however, a powered USB hub may be utilized to connect multiple RPs to your PC to update several at a time. If you are doing this, be sure all RPs are connected prior to Step 7.

- Click the **Scan For Devices** button at bottom of the tab.
- Click the **Update** button. A progress bar will display.
- Wait for the device to complete its update process. DO NOT disconnect the device or click **Abort** until all of the device's updates are complete and an "Update Complete" message displays in the progress bar. Click the **Clear** button to remove that device from the list.

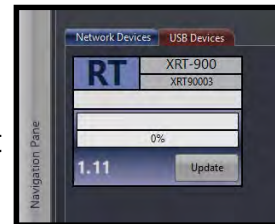

Figure 52: Connected Device

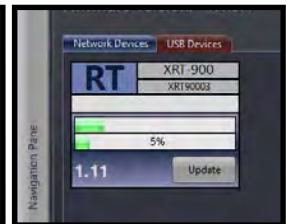

Figure 53: Device Firmware In Progress

NOTE: When updating a CU, the CU will reboot; you should wait for the CU front panel to also display an "Upload Complete" message before continuing to step 11.

NOTE: When updating Antennas, wait for the RX and TX LEDs to finish alternating flashes and return to a normal state before continuing to step 11.

- Verify the firmware installation by repeating step 7 to rescan the device. Confirm that the rescanned device's box now displays the new firmware version number in X-Ware.
- Disconnect the USB cable from the device without clicking on anything in X-Ware. Once the device is disconnected, click the **Clear/Abort** button on the device box to remove the device from the Firmware tab.
- Repeat steps 6–11 above until each Control Unit (CU), Radio Transceiver (RT), and Radio Pack (RP) is updated.

NOTE: After updating your CU, you may notice that the CU's LCD displays a device incompatibility message. This is because your Antennas (RTs) have not yet been updated to the new version. The CU message will clear on its own as you continue with the Antennas' firmware updates.

Connecting X-Ware to Your CU

Follow the steps below to connect your X-System to your PC so that you can use X-Ware on game day as a real-time monitoring tool.

1. Right-click your PC's connection icon and select **Open Network and Sharing Center**. (Or access the same window from your PC's Control Panel.)
2. Click **Local Area Connection** near the upper right of the window. The Local Area Connection Status window will display.
3. Click **Properties**. A Local Area Connection Properties window will display.
4. Double-click the **Internal Protocol Version 4 (TCP/IPv4)** option from the list of connection properties. A TCP/IPv4 Properties window will display.
5. Click the radio button beside **Use the following IP Address**, then type **192.168.10.99** in the field. Click **OK**.

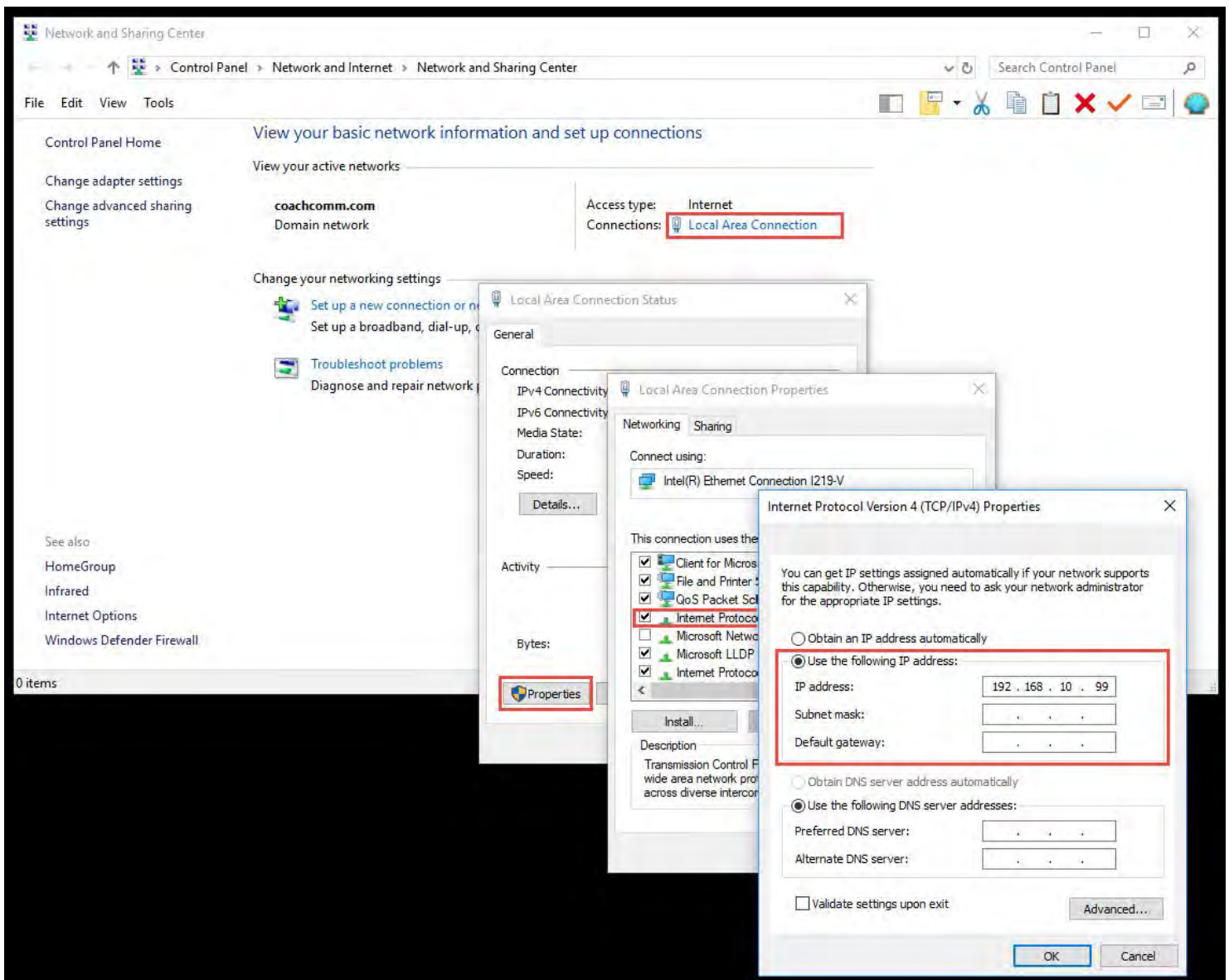

Figure 54: Changing PC IP Address

6. Connect a Cat 5 cable from your PC to the LAN port on the rear of the X-System CU (in the Press Box Rack Unit.) See page 15 for a diagram of the CU rear and the location of the LAN port.
7. Complete the procedures detailed in the Game Day Setup section on page 5 of this manual.
8. Double-click on the X-Ware icon on your desktop to open X-Ware. X-Ware will open and connect to the CU, and you will be able to view the real-time status of all connected and paired X-System devices from X-Ware. See page 43 for more information about X-Ware Operation.

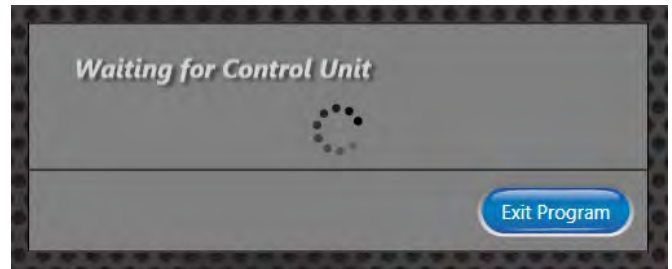

Figure 55: Waiting for Control Unit X-Ware Screen

Note: If X-Ware is not connected to your CU or if the CU is not powered on, you will see the following message when you open the game day interface of X-Ware: “Waiting for Control Unit.”

Enabling Game Day Interface

Sometimes Windows 10 PCs open X-Ware to the Advanced Settings interface instead of the Game Day Interface depicted in Figure 57 on page 43.

To modify X-Ware’s startup behavior to show the Game Day Interface when opened, follow the steps below:

1. Right-click the X-Ware icon on your PC’s desktop and choose **Run as Administrator**.
2. Once X-Ware is open, click **Edit**, then **Configuration**, then **Communication Settings**. A dialog box will display.
3. Click the checkbox beside **X-Cart**, then click **OK**.
4. Close X-Ware. The next time you open X-Ware, the game day interface will display.

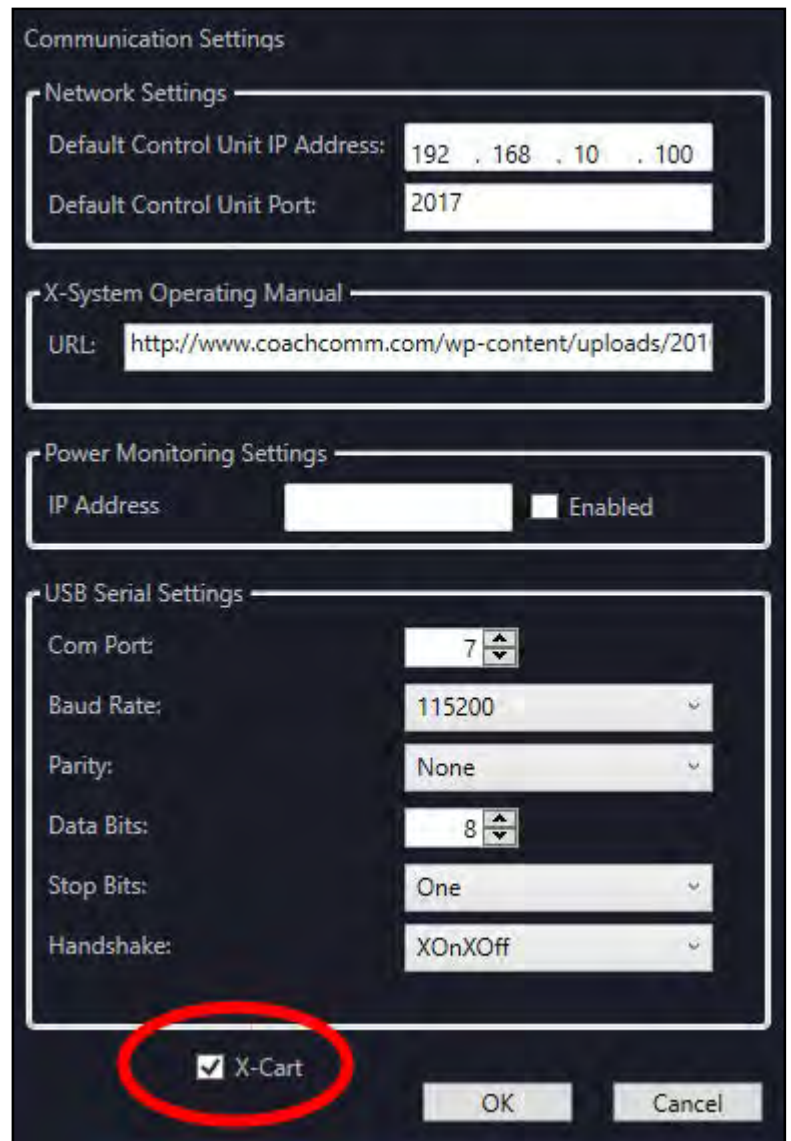

Figure 56: Checkbox to Enable X-Ware Game Day Interface

X-Ware

X-Ware is X-System's proprietary intercom management software, and its easy-to-use touch screen interface provides fast access to critical information and settings, allowing efficient management of large systems.

Within X-Ware, you can manage user settings, set up and manage profiles, assign dry pairs, and access system diagnostics.

Home Screen

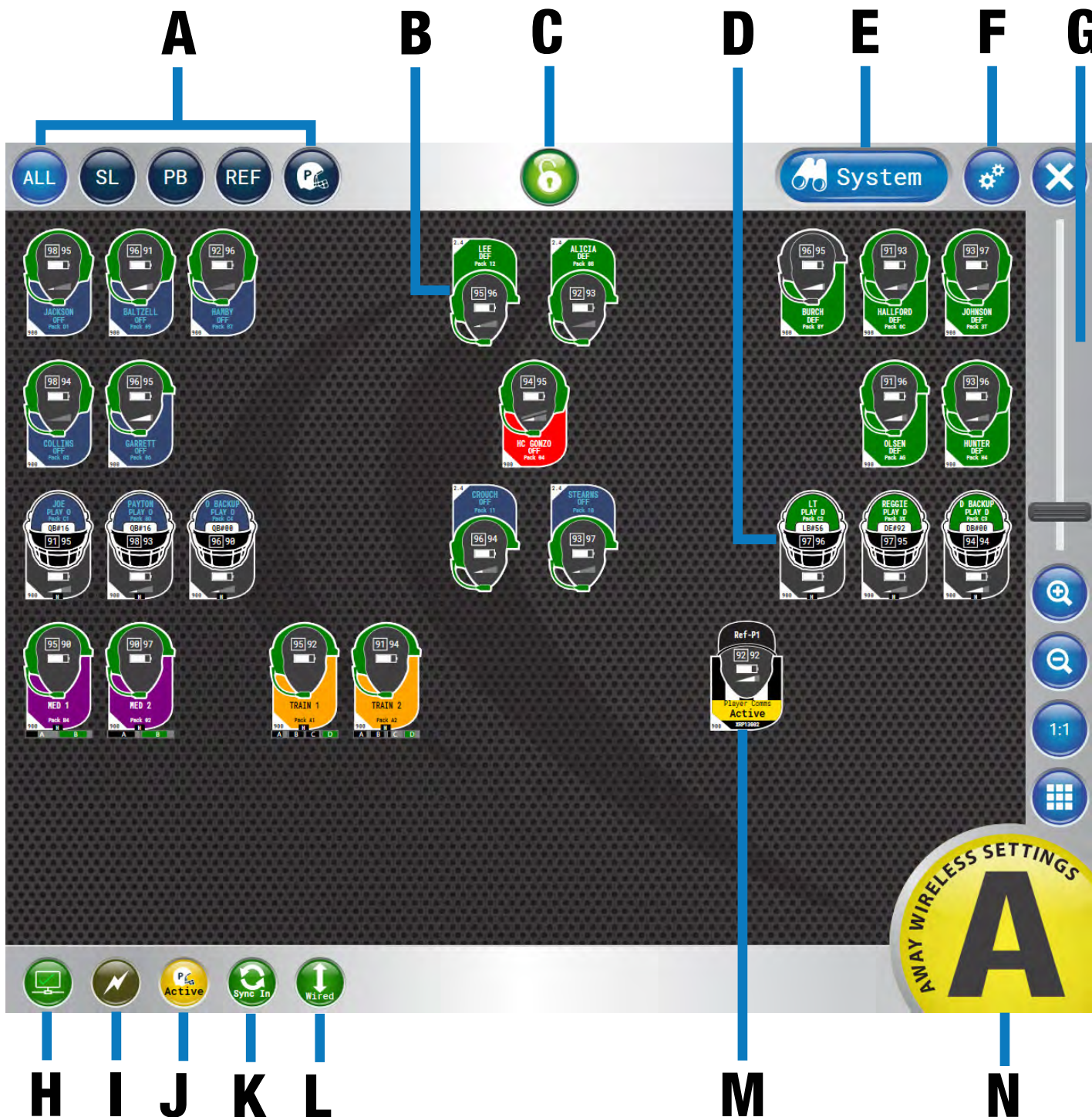

Figure 57: X-Ware Home Screen

When X-Ware opens, the Home screen displays an overview of icons that represent all Radio Packs (RPs) on the system and their current status on the system. This is the default screen that displays during game time. If this screen does not display when you open X-Ware, see “Enabling Game Day Interface” on page 42.

- A. **Icon Filter Buttons** - Shows all RP icons, sideline (“SL”) icons, or press box (“PB”) icons.
- B. **Coach RP Icon** - Contains the Profile Name, Active Conference, Pack Name, and indicators for link quality, battery, volume, and frequency. The icons can be positioned to your liking by dragging them to a location on the screen.
- C. **Lock-Out Button** - Locks X-Ware. If a passcode has been set up by a system administrator, unlocking requires passcode entry. This prevents unauthorized access. See page 61 for more.
- D. **X-Player Icon** - Contains the Profile Name, Active Conference, Pack Name, Player Position & Number, and indicators for link quality, battery, volume, and frequency. The icons can be positioned to your liking by dragging them to a location on the screen.

Note: *Products and software associated with X-System Player and Referee Interrupt are only functional with the X-System Player upgrade package.*

- E. **System Button** - Opens X-Ware’s additional Radio Transceivers, Radio Packs, and Conference views.
- F. **Advanced Settings Button** – X-Ware’s Advanced Settings interface is where the core operational settings for the system configuration reside. Changes to these settings can impact system performance if made improperly. In particular, changes to these settings during “live” operation on game day should be avoided. It is highly recommended you contact CoachComm Customer Support prior to game day if changes are desired.
- G. **Zoom** – Slider bar and other view options allow you to adjust the magnification of the Home Screen view.
- H. **CU LAN Indicator** – Green illumination of this indicator confirms that the Control Unit (CU) and X-Ware are connected and communicating. When not illuminated, an “X” will appear in the indicator meaning the CU is not connected to X-Ware.
- I. **Sideline Cart Power Status Indicator** - X-Ware has no power status indicator for the Press Box Unit; therefore, this indicator may be absent or may appear grayed out in a local Press Box configuration.
- J. **Player Communications Status Indicator** - Yellow illumination of this indicator confirms that player communications are active. When illuminated red, player communications have been muted by the referee.
- K. **Sync Connection Status Indicator** - Green illumination of this indicator confirms that sync is connected.
- L. **Wired Interface Status** - Green illumination of this indicator means that all wired connections are active. Red indication (with black diagonal line) indicates that at least one wired connection has been turned off.
- M. **Referee Interrupt RP Icon** - Contains the Profile Name, Pack Name, Communication Status of X-System Player, and indicators for link quality, battery, volume, and frequency. The icons can be positioned to your liking by dragging them to a location on the screen.

Note: *Products and software associated with X-System Player and Referee Interrupt are only functional with the X-System Player upgrade package.*

- N. **“Away” Indicator** – If your system is set as the “Away” team, a yellow Away indicator will display in the bottom right-hand corner of the Home screen. If your system is set as the “Home” team, no icon will display.

Not Pictured: Audio Recording Status Indicator - See “Audio Recorder” on page 52 for more information.

RP Icons

The RP Icon represents each individual Radio Pack and X-System Player on the Home Screen and RP Profile Screen. The icon appearance can be customized from the Profile Management tab in X-Ware’s advanced settings; see “Customizing RP Icon” on page 57 for more information about that process.

Coach RP Icon

The icon’s headset illuminates green when talk is active. The entire icon will glow red when the RP’s battery is low. The icon color can be customized via the Group Management tab in X-Ware’s advanced settings; see “Customizing RP Icon” on page 57.

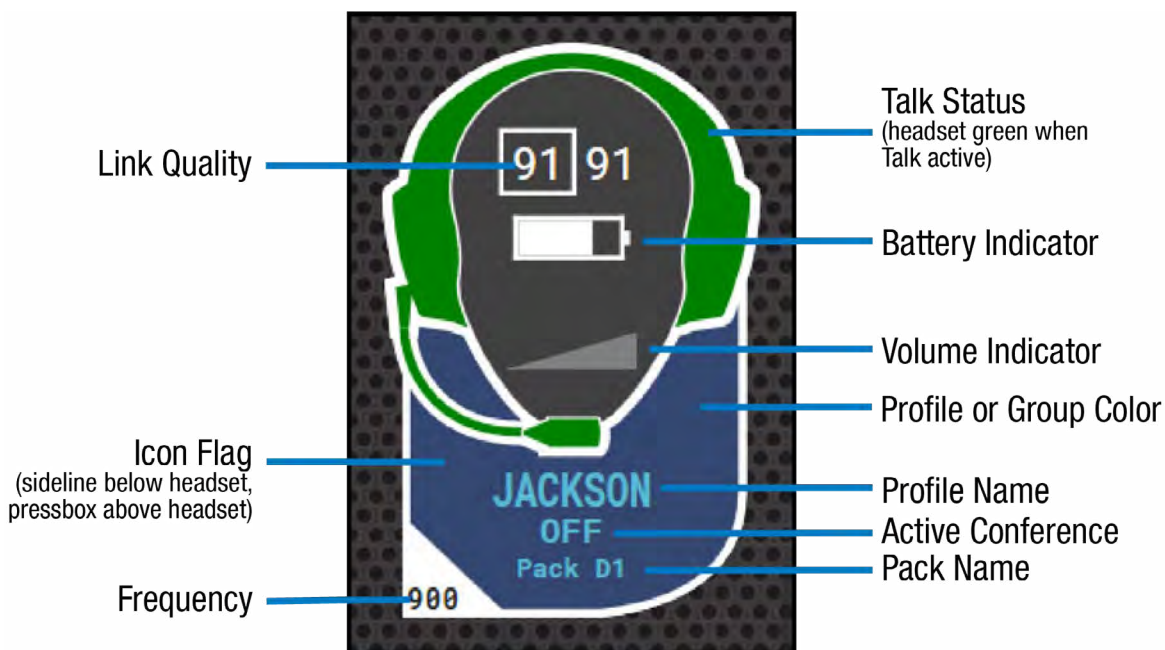

Figure 58: X-Ware Coach RP Icon

High Density-enabled RPs will show a small “H” at the bottom of the icon flag. The XRP-22 and XRP-44 will show the conferences underneath the icon flag. The Conference box is gray with low volume and Talk off. As the volume is increased on the conference, the box will turn black from left to right. When Talk is on, the box will illuminate green. See Figure 59 for examples of both.



Figure 59: RP Icon of XRP-44 in High Density Mode

X-System Player Icon

The icon's flag illuminates red when communication to the X-System Player is muted by the referee. The entire icon will glow red when the RP's battery is low. The icon color can be customized via the Group Management tab in X-Ware's advanced settings; see "Customizing RP Icon" on page 57.

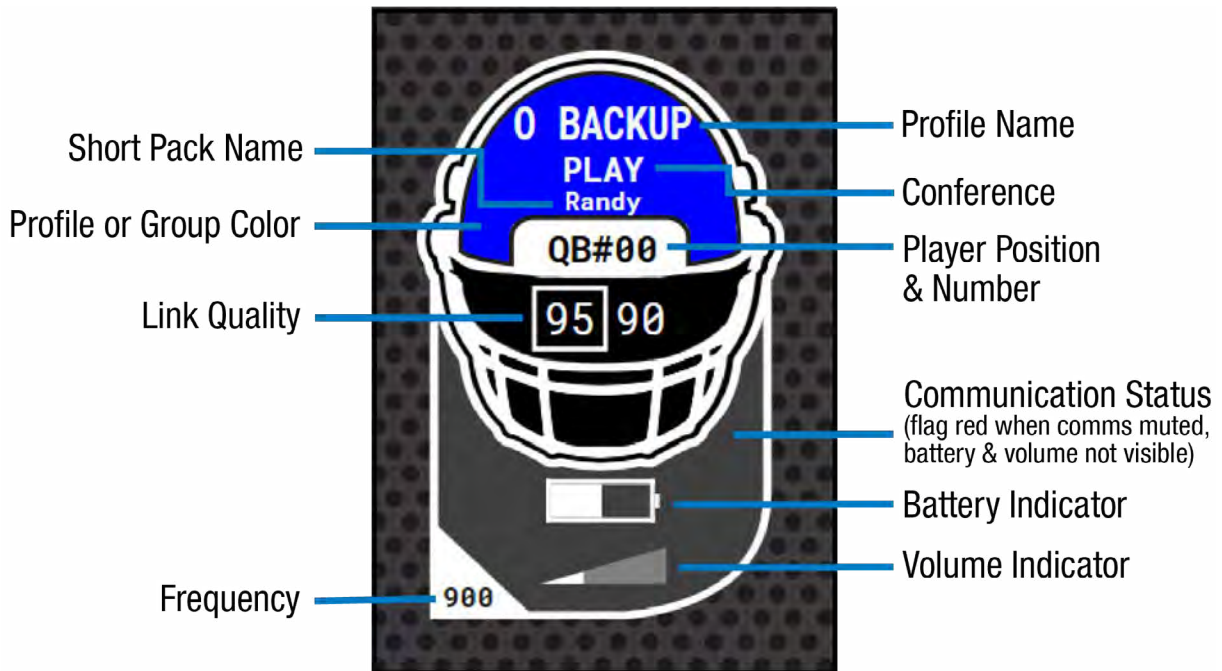

Figure 60: X-Ware X-System Player Icon

Referee RP Icon

The icon's yellow flag illuminates red when communication to the X-System Player is muted by the referee. The entire icon will glow red when the RP's battery is low. The icon color can be customized via the Group Management tab in X-Ware's advanced settings; see "Customizing RP Icon" on page 57.

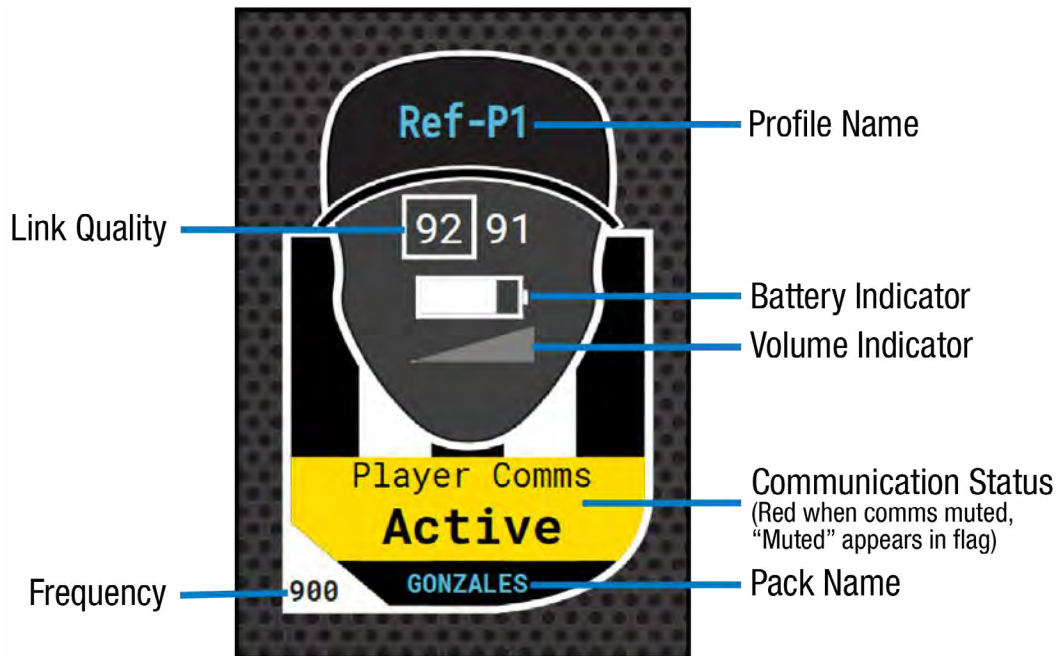

Figure 61: X-Ware Referee RP Icon

Profile Screen

Access the RP Profile screen from the System button or by tapping/clicking on a particular RP icon from the Home screen. This view provides details about the selected RP, including a “live” view of that RP’s real-time display and available conferences. From this screen, you can view the RP status, assign conferences, assign a new profile, view conference members, and show the RP user’s accessibility to other members.

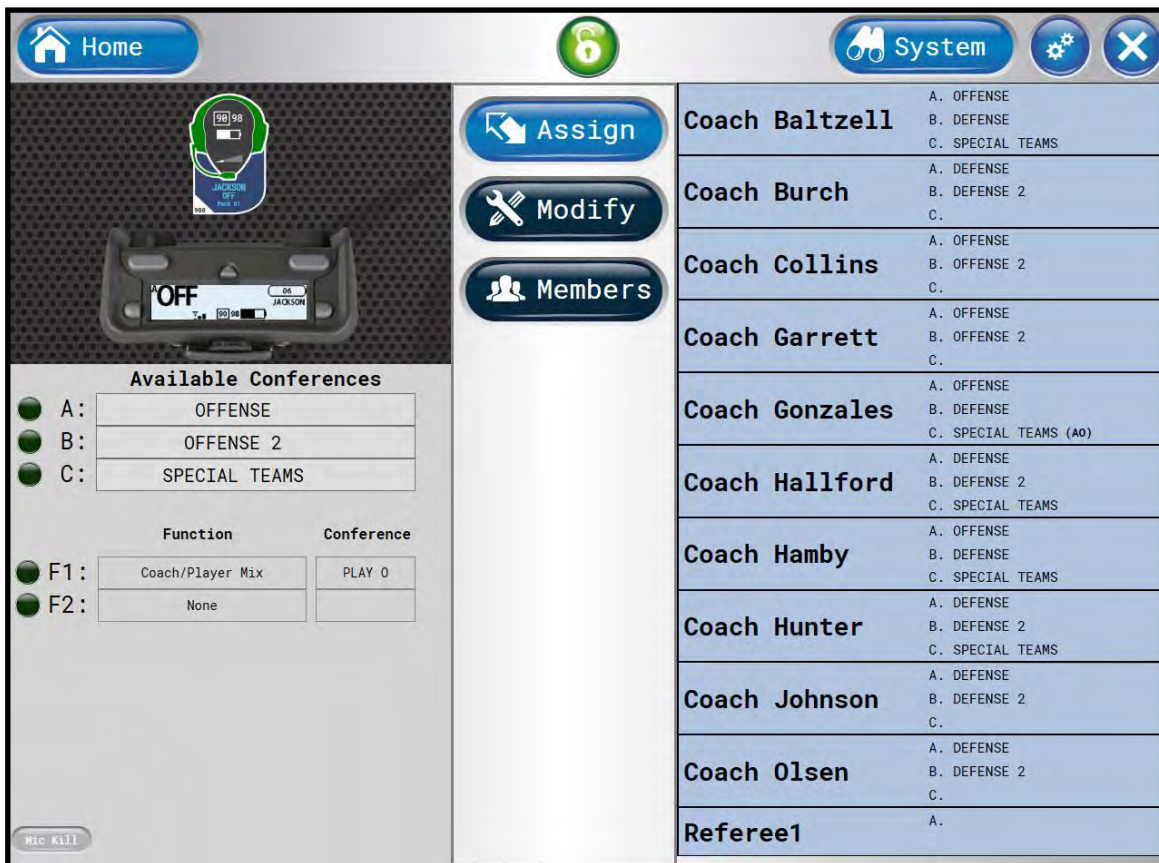

Figure 62: X-Ware RP Profile Screen

Note: Changes to the Function Button assignments shown in the image above can only be made in X-Ware Advanced Settings and not in this screen. The F1/F2 display is for status only.

Assigning New Conferences

The list of available conferences on the RP Profile Screen displays the conferences currently assigned to that RP’s Profile. An illuminated green indicator shows the RP’s current active conference.

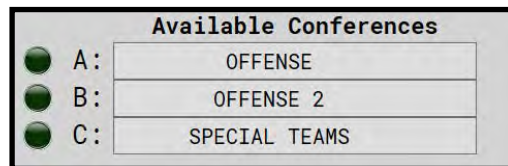

Figure 63: RP Profile Screen’s Available Conferences List

You can quickly edit these assigned conferences by tapping/clicking on any conference and selecting the new assignment from the conference list that displays.

Note: If you change a conference on a profile, all Radio Packs with that profile will change also.

Once a Referee profile is assigned to an RP, the pack must be re-paired before it can be assigned a coach profile. Products and software associated with X-System Player and Referee Interrupt are only available with the X-System Player upgrade package.

Mic Kill

The Mic Kill button on bottom left the RP Profile Screen allows you to remotely turn off the selected RP’s active Talk.

Note: Not available for Always On and Disable Talk button modes.

Assigning New Profiles

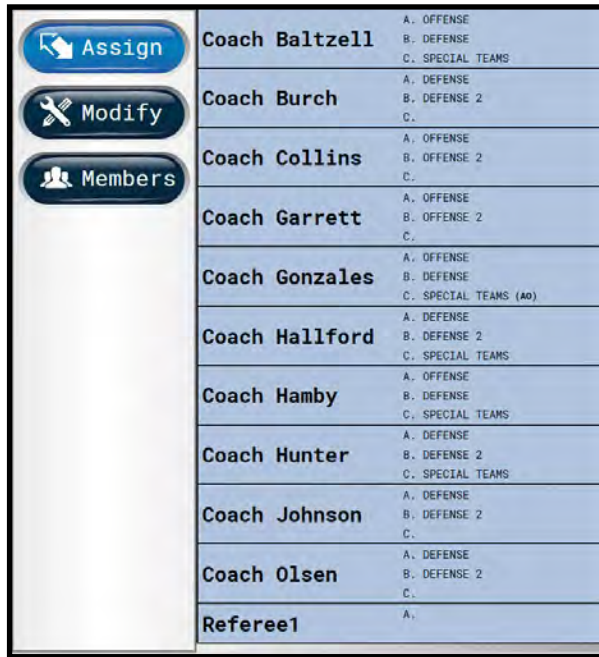

Figure 64: X-Ware Assign Profile View

The Assign button enables you to quickly assign a new profile to the selected RP. The right-hand list displays the available profiles for the type of RP selected (i.e., only 900MHz profiles will display if you selected a 900MHz RP, only XRP-13 profiles will display if you select an XRP-13 RP. etc.). To change the profile, tap/click the desired profile from the list. Confirm your selection on the prompt that displays. You can choose whether to load user settings from the new profile or retain the selected RP's current user settings. (User settings include the items listed under the "Modify" view. See page 48 for more information.)

If needed, you can also change an RP's profile assignment from the Control Unit menu; see page 34 for more information.

Modify Settings



Figure 65: X-Ware Modify Settings View



Figure 66: X-Ware XRP-22 & XRP-44 Modify Settings View

The Modify button displays a list of User Settings that can be customized for the selected RP. You can choose to retain the profile's default settings or customize the settings once the profile is applied. The XRP-22 and XRP-44 Volume sliders are vertical to allow for all volume options (only 2 sets of sliders will show on XRP-22 settings).

The settings available on this screen will be different for X-System Player and Referee Interrupt packs. See "Appendix A: CoachComm X-System Coach to Player Communication" on page 83 for more information on X-System Player.

Note: Products and software associated with X-System Player and Referee Interrupt are only functional with the X-System Player upgrade package.

Members View

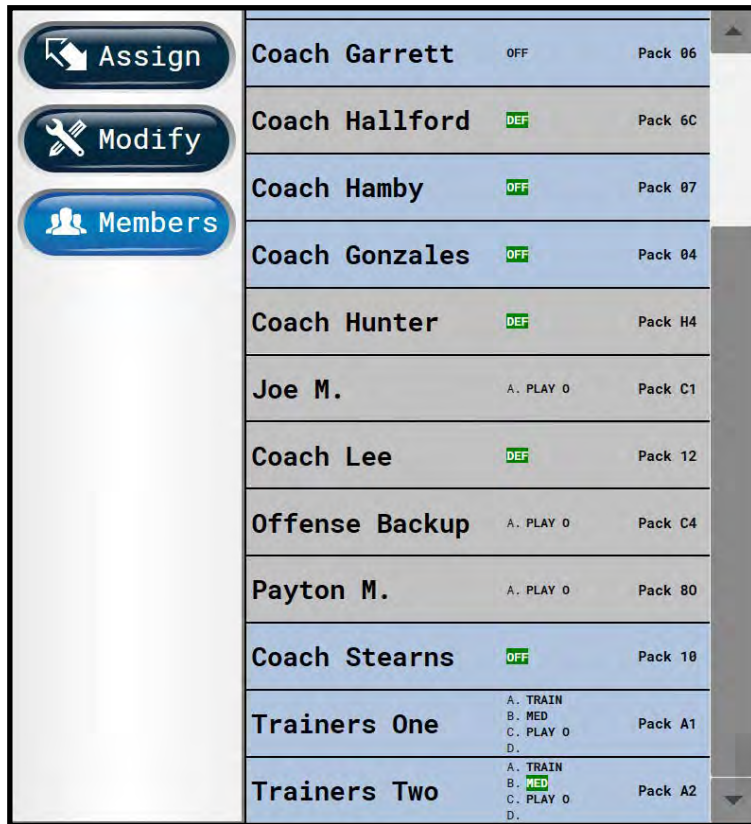

Figure 67: X-Ware Members View

The Members button enables you to view a list of all users the selected RP has access to. Users not on the selected RP’s active conference will be grayed out with black text. RPs that are not logged in will be grayed out with gray text.

Clicking one of the users on the list will take you to that user’s RP Profile view.

Additional System Views

Radio Transceivers View



Figure 68: X-Ware Radio Transceivers View

The Radio Transceivers view provides information for each RT currently connected to your X-System.

This view also provides another place to view your system’s “Home” or “Away” setting. (For more information about this setting, see page 33.)

Each RT icon displays the RT’s name, hopping pattern, mode, and frequency. Each paired RP displays to the right of its RT icon, and their icons display the device status (green for normal, red for error), RP name, link quality, profile name, and active conference. (The conference displays green when the talk button is active.)

Note: High Density RT rows will show details of only the RPs that are currently using one of the four talk slots. Other RPs logged in to that RT will be counted to the right of the talk slots.

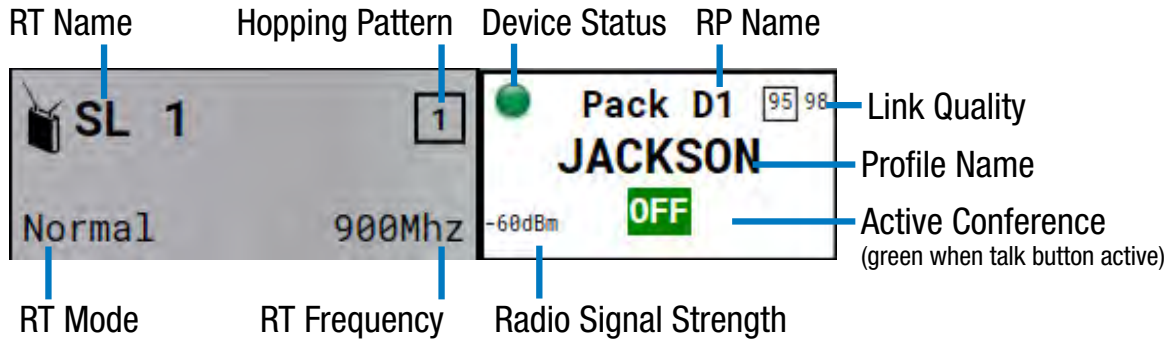

Figure 69: Radio Transceiver View Detail

Radio Packs View

RP Profile	Current RT	Active Conf	LQ	LQ	RSSI	Batt	Conf A	Conf B	Conf C	Conf D	Pack Name
BALTZELL	SL 1 Normal 900Mhz	OFF	92	96	-70 dBm	14h:36m	OFF	DEF	SP TMS		Pack 09
BURCH	SL 2 Normal 900Mhz	DEF	98	97	-50 dBm	14h:36m	DEF	DEF 2			Pack 8Y
COLLINS	SL 1 Normal 900Mhz	OFF	94	94	-60 dBm	14h:36m	OFF	OFF 2			Pack 05
D BACKUP	SL HD 4 High Density 900Mhz	PLAY D Player Comms Active	98	94	-50 dBm	14h:36m	PLAY D				Pack C3
GARRETT	SL 1 Normal 900Mhz	OFF	93	96	-70 dBm	14h:36m	OFF	OFF 2			Pack 06
HALLFORD	SL 2 Normal 900Mhz	DEF	98	91	-50 dBm	14h:36m	DEF	DEF 2	SP TMS		Pack 6C
HAMBY	SL 1 Normal 900Mhz	OFF	92	93	-70 dBm	14h:36m	OFF	DEF	SP TMS		Pack 07
HC GONZO	SL 1 Normal 900Mhz	OFF	95	93	-60 dBm	14h:36m	OFF	DEF	SP TMS		Pack 04
HUNTER	SL 2 Normal 900Mhz	SP TMS	90	98	-70 dBm	14h:36m	DEF	DEF 2	SP TMS (A0)		Pack H4
JACKSON	SL 1 Normal 900Mhz	OFF	0	0	-128 dBm	14h:36m	OFF	OFF 2	SP TMS		Pack D1
JOE	SL HD 4 High Density 900Mhz	PLAY 0 Player Comms Active	93	90	-70 dBm	14h:36m	PLAY 0				Pack C1
JOHNSON	SL 2 Normal 900Mhz	DEF	92	93	-70 dBm	14h:36m	DEF	DEF 2			Pack 3T
Jones	SL 3 Normal 900Mhz	OFF	90	96	-70 dBm	14h:36m	OFF	DEF	SP TMS (A0)		Pack X0
LT	SL HD 4 High Density 900Mhz	PLAY D Player Comms Active	90	94	-70 dBm	14h:36m	PLAY D				Pack C2
MED 1	SL HD 4 High Density 900Mhz	A B	95	97	-60 dBm	14h:36m	MED	TRAIN			Pack B4

Figure 70: X-Ware Radio Packs View

The Radio Packs view provides a list of active RPs, along with the following information about each one: Profile Name, Current RT, Current Conference, LQ, RSSI value, Remaining Battery Time, Assigned Conferences, and Radio Pack device name.

This list can be sorted by clicking on any column header. You can also filter the list by clicking on **All**, **Sideline**, or **Press Box**, and add additional filter groups if desired by using the Group Management feature. (See page 57 for more information about Group Management.)

You can also click on any RP in the list to access that RP's Profile View.

Conferences View

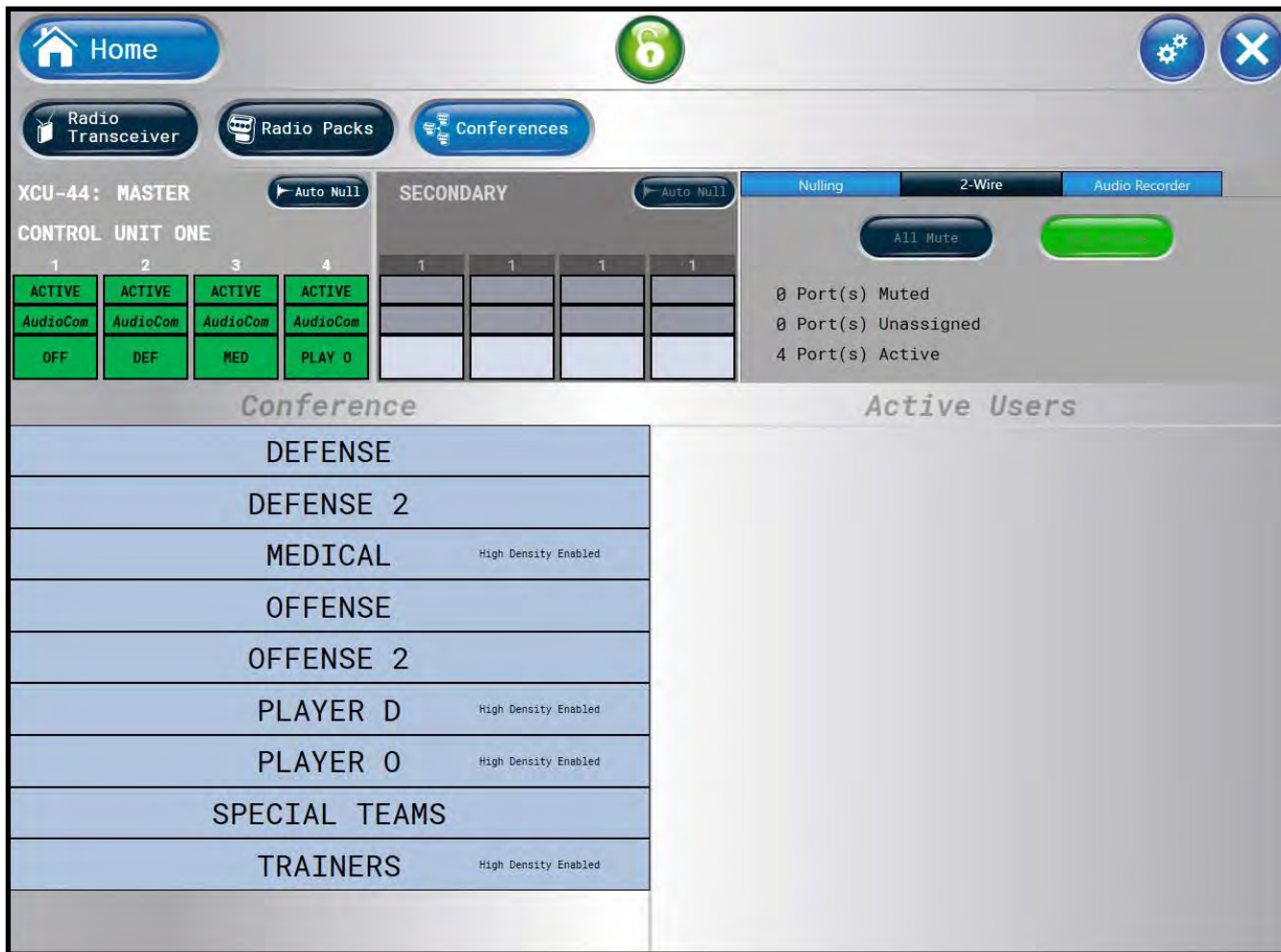

Figure 71: X-Ware Conferences View

The Conferences view displays a list of the system’s conferences and dry pair connections.

Clicking a conference from the list will display the active users on that conference in real time.

Move a conference assignment from one dry pair to another by selecting the dry pair (turning it yellow) and then selecting the new conference assignment. Confirm your change in the pop up that displays. You can also assign conferences to dry pair connections from the CU; see page 34 for details on that process.

Note: Red colored icons (Conferences, the ports, and the Wired Interface Status icon) indicate that at least one port is muted.

Audio Recorder

The Audio Recorder function allows for one conference to be recorded on the system's PC. These audio files (.mp3) can then be used for further off-line evaluation or for troubleshooting when necessary.

To record audio, choose the source (Src) for the audio output (the audio meter will indicate the presence of audio once a source is chosen regardless of recording status). Choose one conference to record in the A selection. Click REC to record the selected conferences. A tray icon with REC will appear when audio is recording (See Figure 73). To stop the recording, click the REC button that now shows a white square.



Figure 72: Audio Recorder

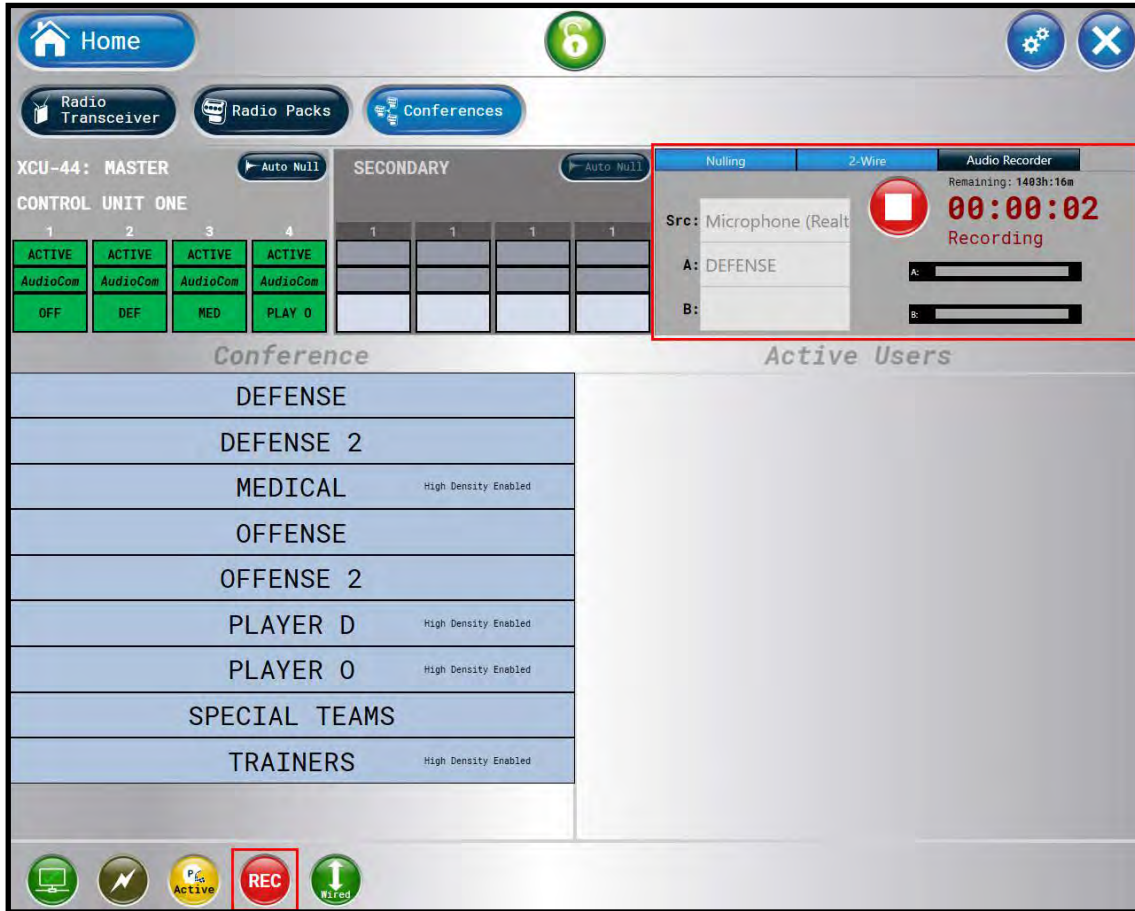

Figure 73: Audio Recording in Progress

Note: Audio Recorder function requires installation of 6-Foot 3.5mm TRS to Dual 1/4 in. TS Stereo Audio Breakout Cable (CAB-6MTRS-C2R) into X-System.

The MP3 file will be saved to the computer desktop in a folder labeled “CoachComm-Recordings”. The file name will be labeled as follows: “CCFNAME_YYYYMMDD_AorB_ConferenceLongName_HHMMSS.mp3”.

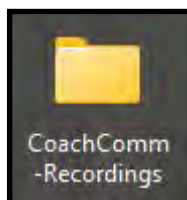

Figure 74: Audio Recording Folder on Desktop

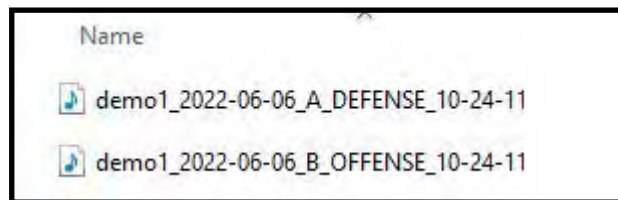

Figure 75: Example Audio Files

Auto Null Process

Nulling is required to electronically balance an audio device, in this case a Control Unit, with a 2-wire intercom system.

Important! This procedure **MUST NOT** be performed while the system is in use in a game environment. This process uses audible tones that will disrupt communication between users.

1. Ensure that all sideline and press box units are connected via stadium wiring and that wired BeltPacks are connected to the press box system prior to nulling.
2. Using X-Ware, null each Control Unit, one at a time, at initial system setup.

Note: You may also null a system from the Control Unit menu without X-Ware. The **Run Auto Null** command is found under the Wired Settings menu.

The Auto Null function is available from the Conferences View in X-Ware. To null a Control Unit, follow the steps below:

1. Select the Auto Null button on the Control Unit you wish to null.



Figure 76: X-Ware Auto-Null Command

2. Confirm your decision to auto null on the prompt that displays.
3. Once nulling begins, a nulling status screen will display, indicating that null is in process on the Control Unit's port indicated in red.



Figure 77: X-Ware Auto-Null In Progress

X-Ware Advanced Settings

X-Ware's Advanced Settings interface is where the core operational settings for the system configuration reside. Changes to these settings can impact system performance if made improperly. In particular, changes to these settings during "live" operation on game day should be avoided.

Opening a System Configuration File Offline

You can edit a previously saved System Configuration File in X-Ware to make offline edits.

To open a saved configuration file:

1. Hold down the CTRL key on your keyboard and click on the X-Ware desktop icon. (Hold down the CTRL key until the program opens, then release it.) This bypasses the Control Unit connection function, and allows X-Ware to open in an offline state directly to the Advanced Settings view.
2. Click the **Open File** shortcut button in the top left corner of the screen. A windows directory browser will open.

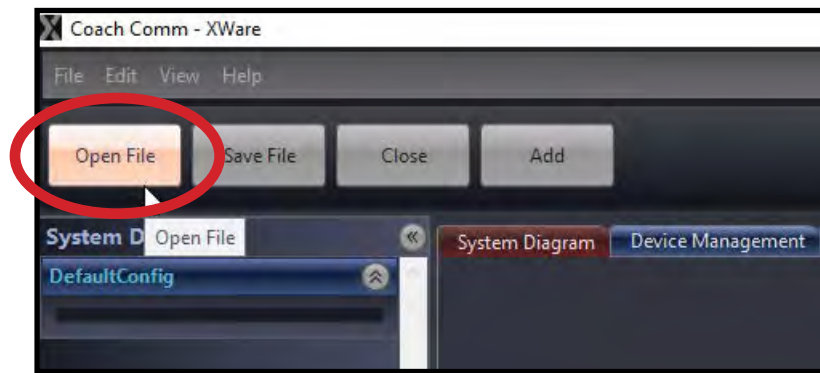

Figure 78: Open Saved .pcf File

3. Navigate to the location of your saved .pcf file, and open it.
4. Use X-Ware's advanced settings functions to make edits to the file. When your edits are done, save the .pcf and load it to your CU using the procedures detailed on page 65.

Ping Devices

RP Ping Device (button in Device Detail View and in Device Management List View) Device location function where, when activated, will cause the backlight of the selected RP's LCD display to blink until deactivated by the operator.

RT Ping Device (button in Device Detail View and in Device Management List View) Device location function where, when activated, both the top ping light and the mode LED on the bottom of the RT will blink until deactivated by the operator.

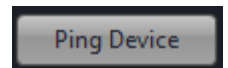

Figure 79: Ping Device Button

View Paired Radio Packs per CU

Radio Pack pairings can be viewed in X-Ware under Device Management > Control Units. The pairings are to the right of each CU in the system.

 A screenshot of the X-Ware interface showing the "Radio Pack Pairings List" under "Device Management > Control Units". The interface includes a menu bar with "System Diagram", "Device Management", "Conference Management", "Profile Management", "Group Management", "Event Log", and "Firmware". Below the menu bar are several tabs: "Control Units", "Radio Receivers", "Radio Packs", and "Hubs". The "Control Units" tab is active, showing a table of control units. The table has columns for "Long Name", "Type", "Audio Status", "Port Name", "Conference", "Type", "Audio Mode", "Port Name", "Long Name", "Short Name", "Model", "RT Mode", and "Serial Number". The table contains four rows of data for different control units.

Figure 80: Radio Pack Pairings List

Unpair Radio Packs

Radio Packs can be unpaired from the CU Menu in the Paired RP List or in X-Ware by right-clicking the Radio Pack in the RP and choosing Unpair.

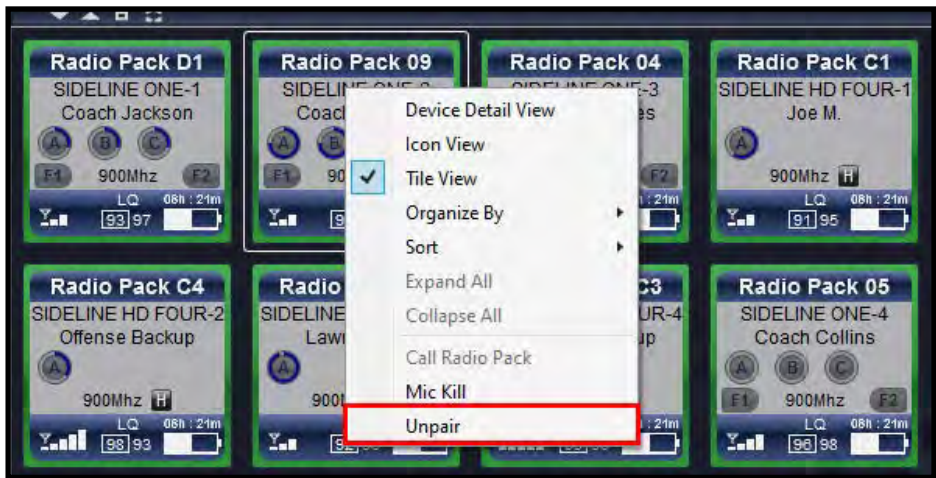

Figure 81: Unpair RPs Option in Advanced Settings

Note: RPs with a Referee profile cannot be unpaired from X-Ware and must be unpaired via CU.

Adding a Conference

Use the procedures below to add a conference to your X-System configuration. For information on assigning conferences, see “Assigning New Conferences” on page 47 and “Changing Conference Port Assignments” on page 34.

1. Open X-Ware and access the Advanced Settings window.

Note: You can add a conference to a “live” system or to an “offline” system. If you make the change while offline, you’ll have to first open a saved .ccf file to edit.

2. Click the **Conference Management** Tab. This tab displays a list of the conferences in the open system configuration file.

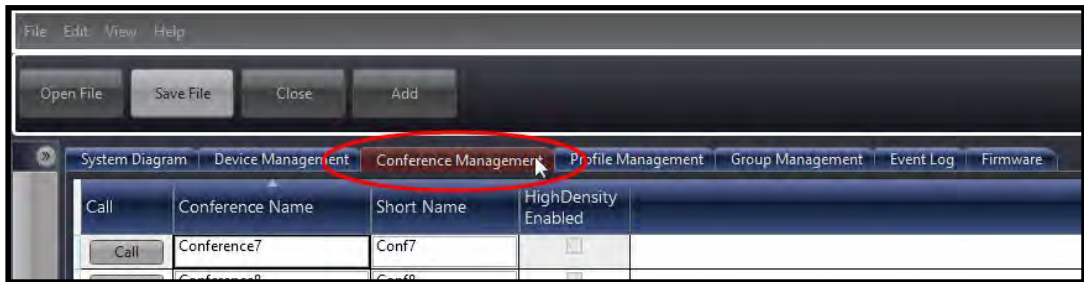

Figure 82: X-Ware Conference Management Tab

3. Click the **Add Conference** button in the bottom left corner of the screen. A new conference will appear in the list.
4. Click in the Conference Name column for the new conference, and type a new long name for the conference. (Limit of 16 characters).
5. Click in the Short Name column, and type a new short name for the conference. (Limit of 8 characters).
6. If you’re editing your .ccf offline, save the .ccf and load it to your CU using the procedures detailed on page 65.

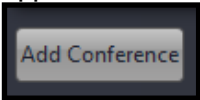

Figure 83: Add Conference Button

Adding a Profile

Use the procedures below to add a profile to your X-System configuration. For information on assigning profiles, see “Assigning New Profiles” on page 48 and “Assign Profiles from the Control Unit” on page 34.

1. Open X-Ware and access the Advanced Settings window.

Note: You can add a profile to a “live” system or to an “offline” system. If you make the change while offline, you’ll have to first open a saved .ccf file to edit.

2. Click the **Profile Management** Tab. This tab displays a list of the profiles in the open system configuration file..

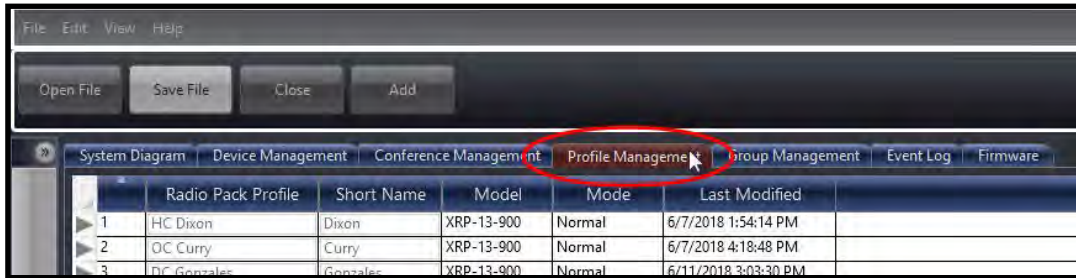

Figure 84: X-Ware Profile Management Tab

3. Click the **Add Profile** button in the bottom left corner of the screen. A new profile will appear in the list.

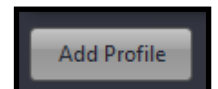

Figure 85: Add Profile Button

4. Double-click on the newly created profile. The profile’s detail screen will display.

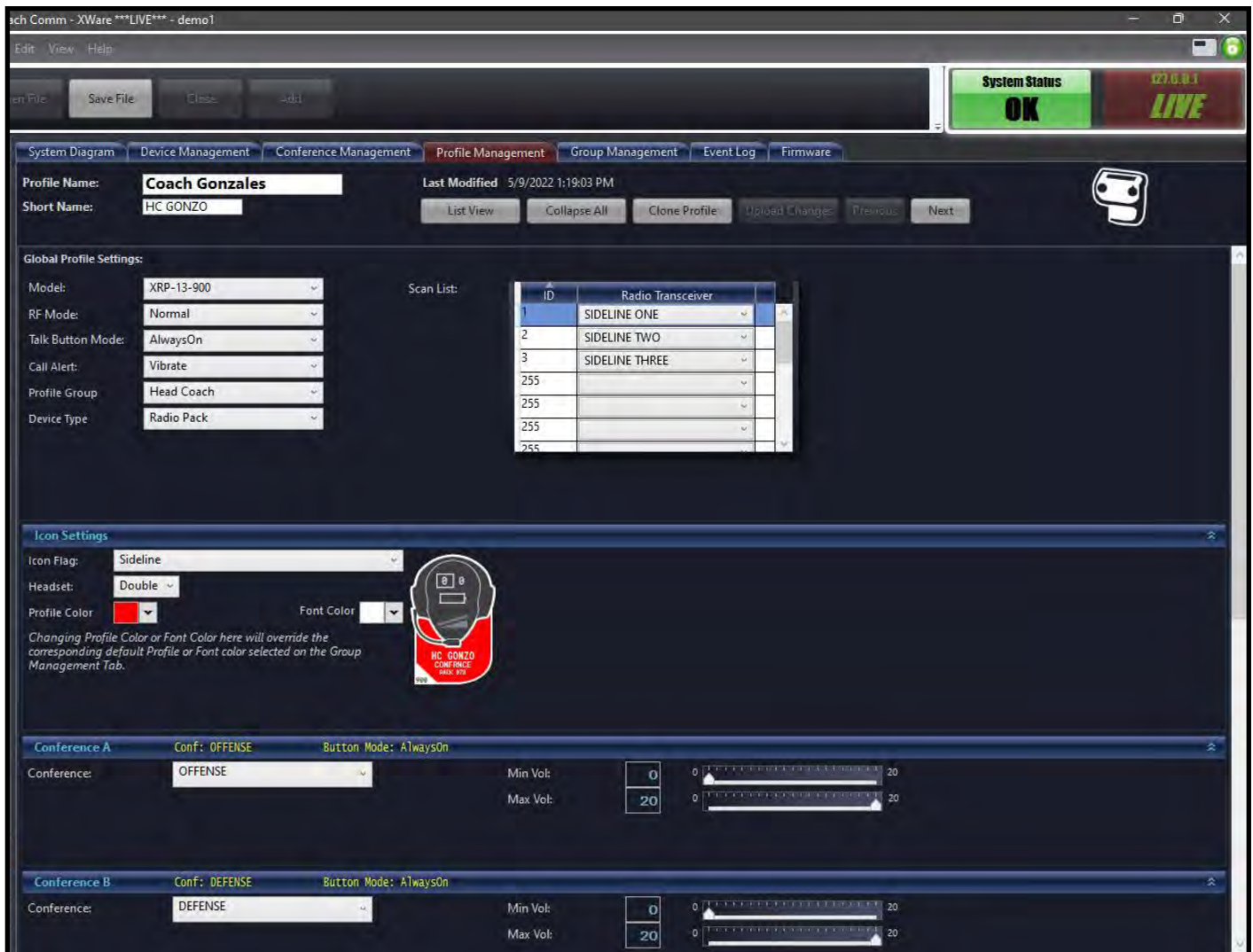

Figure 86: X-Ware Profile Detail Screen

5. Customize the profile settings to fit your needs using the various drop-down and text entry fields on this screen.

Note: Some of the profile settings are not currently used for X-System devices, (e.g., Call Alert and the RP Function Buttons). Leave these fields at their factory default. Other settings are used with X-System, but they **SHOULD NOT** be changed from the factory settings (e.g., Scan List). CoachComm recommends contacting customer support if you have questions about profile settings or configuration details.

6. When your settings are done, click the **Upload Changes** button at the top of the profile detail screen.
7. If you're editing your .ccf offline, save the .ccf and load it to your CU using the procedures detailed on page 65.

Editing or Cloning Profiles

To edit an existing profile, double-click the profile name from the list on X-Ware's Profile Management tab, then complete the desired edit and click the **Upload Changes** button at the top of the profile detail screen. In addition, if you're editing your .ccf offline, save the .ccf and load it to your CU using the procedures detailed on page 65.

To create a copy of the profile, click the **Clone Profile** button at the top of the profile detail screen.

Customizing RP Icon

Customize an RP Icon's shape by changing the **Icon Flag**, **Headset**, **Profile Color**, and **Font Color** fields on the relevant Profile's detail view. Changes will be reflected on every RP Icon for Radio Packs using that profile. In addition, if you're editing your .ccf offline, save the .ccf and load it to your CU using the procedures detailed on page 65.

- **Icon Flag:** Choose from **Sideline** or **Pressbox**, and the icon's curved rectangle area will move above or below the icon's face accordingly.
- **Headset:** Choose from **Single**, **Double**, or **Listen-Only**, and the icon's headset will match the selection. (Listen-only removes the headset's boom, and the headset will never illuminate green for active Talk.)
- **Profile Color and Font Color:** Override the colors determined by the Profile's Group assignment by choosing a color from this field. You can also click on the green circle or the **Restore Colors** button to restore the Profile icon to the Group's colors. See " " on page 57 for more information about Group assignments.

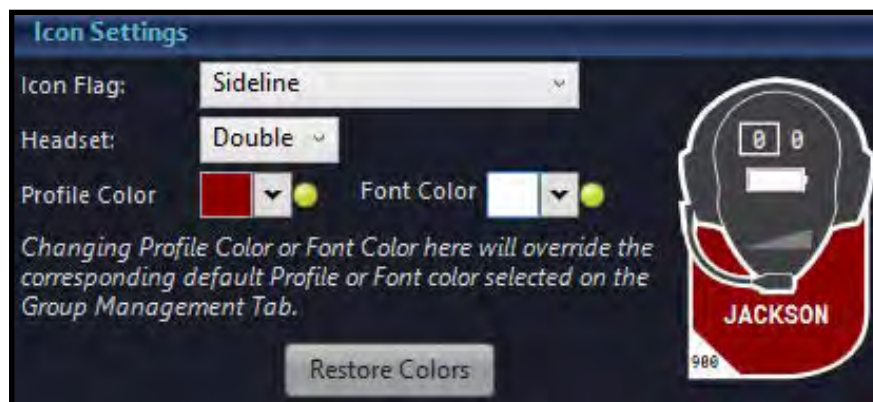

Figure 87: Icon Settings Section of Profile Detail View

Customizing Profile Groups

Use the procedures below to use the Profile Group feature of X-Ware.

1. Open X-Ware and access the Advanced Settings window.

Note: You can add a Group to a “live” system or to an “offline” system. If you make the change while offline, you’ll have to first open a saved .ccf file to edit.

2. Click the **Group Management** Tab. This tab displays a list of the profile groups in the open system configuration file.

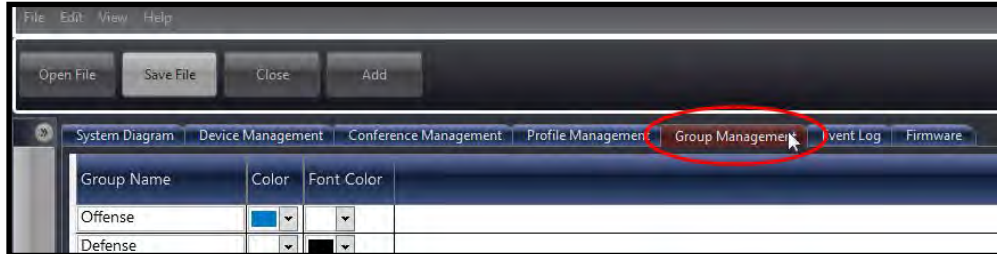

Figure 88: X-Ware Group Management Tab

3. Click the **Add Group** button in the bottom left corner of the screen. A new profile group will appear in the list.

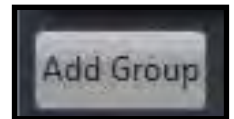

Figure 89: Add Group Button

4. Double-click on the newly created group. The group’s detail screen will display.

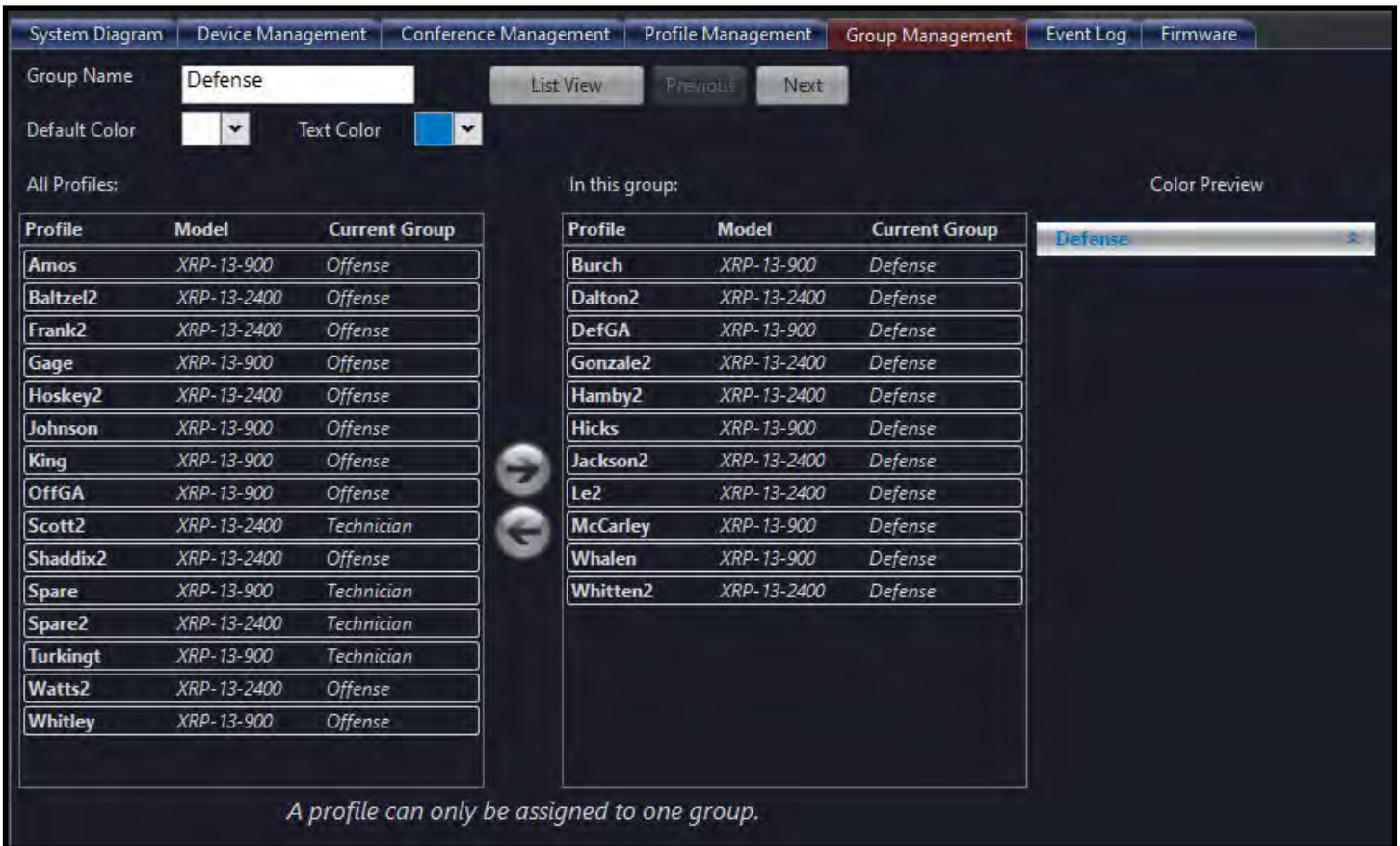

Figure 90: X-Ware Group Detail Screen

5. Click in the Group Name field and type a new name for the group.

- Open the drop-down color pickers in the Color and Text Color fields, and choose a color to represent the group (see Figure 92). The color chosen here appears on the RP Icons (X-Ware’s Home screen) for profiles with the group assignment.

Note: Clicking on the color picker’s **Advanced** tab opens an alternate window where more advanced color options are available. If desired, you may enter hexadecimal color values for an exact color match to your school colors.

- To associate profiles with any group, select them from the All Profiles list on the left-hand column, then use the arrow button to place the selected profiles into the right-hand “In this group” column. You may also open the profile’s detail view and edit the Profile Group field (in the Global Profile Settings section). See Figure 91.

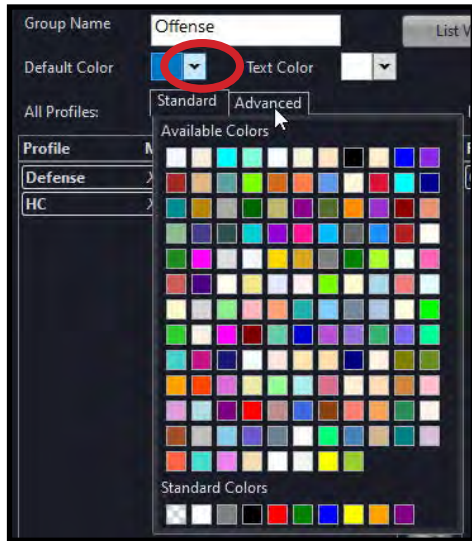

Figure 92: Editing Group Colors

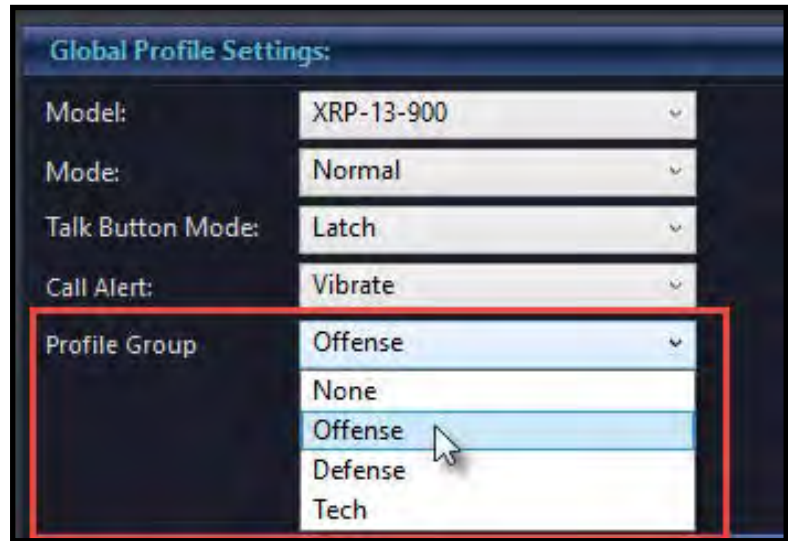

Figure 91: Profile Group Selection - Profile Detail View

- If you’re editing your .ccf offline, save the .ccf and load it to the top CU using the procedures detailed on page 65.

Setting Up Audio Overlay

When Audio Overlay is enabled on a Profile's Conference C, the audio from that Conference will be heard in addition to the audio of the pack's active conference (A or B).

Enable this feature beside **Audio Overlay (AO)** on the relevant Profile's detail view (Conference C only). Confirm your change on the prompt that displays. In addition, if you're editing your .pcf offline, save the .pcf and load it to your CU using the procedures detailed on page 65.



Figure 93: Audio Overlay Toggle on Profile Detail View

When Audio Overlay is enabled on a profile, the **AO Volume** field becomes available on the Game Day Interface (Profile Screen > Modify Settings view). This setting determines the overlaid audio's volume as a percentage of the overall RP volume. AO volume is also indicated on the RP Icon above the volume ramp.



Figure 94: AO Volume Setting on Profile Screen



Figure 95: AO Volume Indicator on RP Icon

Enabling Access Rights

When X-Ware’s Access Rights are enabled, a passcode has been set by the system administrator. If X-Ware is locked while access rights are enabled (using the small padlock icon in the center of the Home screen), X-Ware is “view-only” and the passcode is required to unlock the screen.

Use the following procedures to set a system passcode:

1. Open X-Ware and access the Advanced Settings window.
2. Click **Edit** from the X-Ware Menu.
3. Choose **User Access Rights**, then click **Set Passcode**. A dialog box will display.
4. Enter a unique four-digit passcode for your system in the **Passcode** field, then click **OK**.

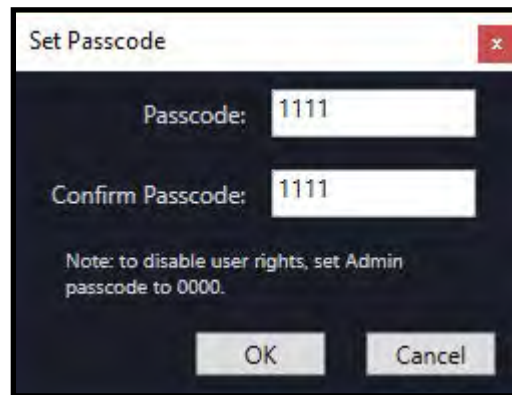

Figure 96: Set Passcode Dialog Box

Note: X-Ware will not require a passcode to unlock if you set the passcode to “0000.”

5. If you’re editing your .ccf offline, save the .ccf and load it to your CU using the procedures detailed on page 65.

Note: Your system may already have a default passcode set up from its original factory configuration. If you experience a locked Home screen at startup following a firmware update, use “1111” as the unlock code. After that, you can set up a new passcode in X-Ware Advanced Settings. Call CoachComm Customer Support for assistance if required.

Sync In Indicators

Sync In Status can be viewed on the CU primary operating screen and in X-Ware. See the images below for Sync In Indicators on the CU menu screen, System Diagram View, CU Management Tab, and top right with the Mini View Toggle and X-Ware Access Rights Lock. The Sync Indicator can also be seen on the X-Ware front end at the bottom (See “Home Screen” on page 43).



Figure 97: Sync In Indicator on CU Primary Operating Screen

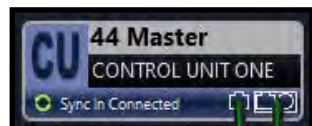

Figure 98: Sync In Indicator on System Diagram CU

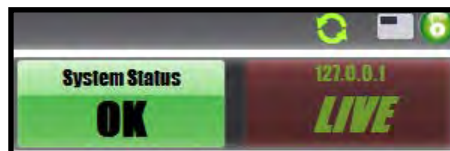

Figure 100: Sync In Indicator on Top Right



Figure 99: Sync In Indicator on CU Management Tab

Operational Modes

High Density Mode is a selectable mode of operation for existing hardware that will allow user densities to increase by more than fivefold.

When selected, this new mode of operation will allow for up to 32 Radio Packs (RPs) or X-System Player Modules to log into a single Radio Transceiver (RT). In addition, users will have the flexibility to mix “Normal” Mode-engaged RPs and RTs along with separate High Density Mode-engaged RPs and RTs on the same system to allow for application specific setup with ultimate adaptability.

***Important!** Normal Mode is the default setting for devices in X-Ware. In order for proper use of Operational Modes, applicable devices and conferences need to be set using the same mode. Specifically, RP profiles and RT RF modes need to be set appropriately, and for High Density mode, up to four conferences need to be assigned as High Density conferences.*

High Density RT Deployment

For best system performance, it is recommended that Normal-mode RTs and High Density-mode RTs be separated. Overall range may be affected as the distance of separation is decreased.

Contact CoachComm Customer Support at 1.800.749.2761 for deployment recommendation.

NORMAL MODE

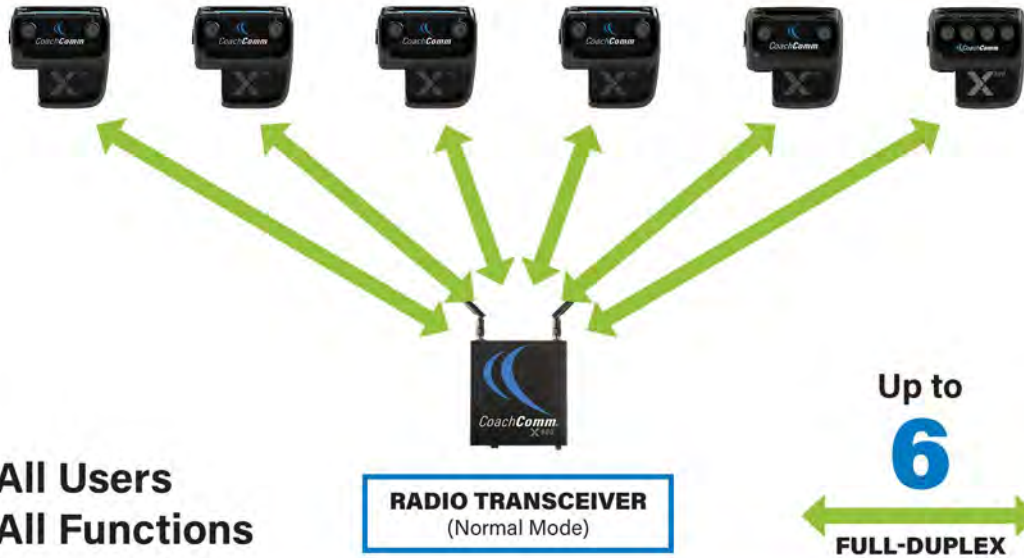

HIGH DENSITY MODE

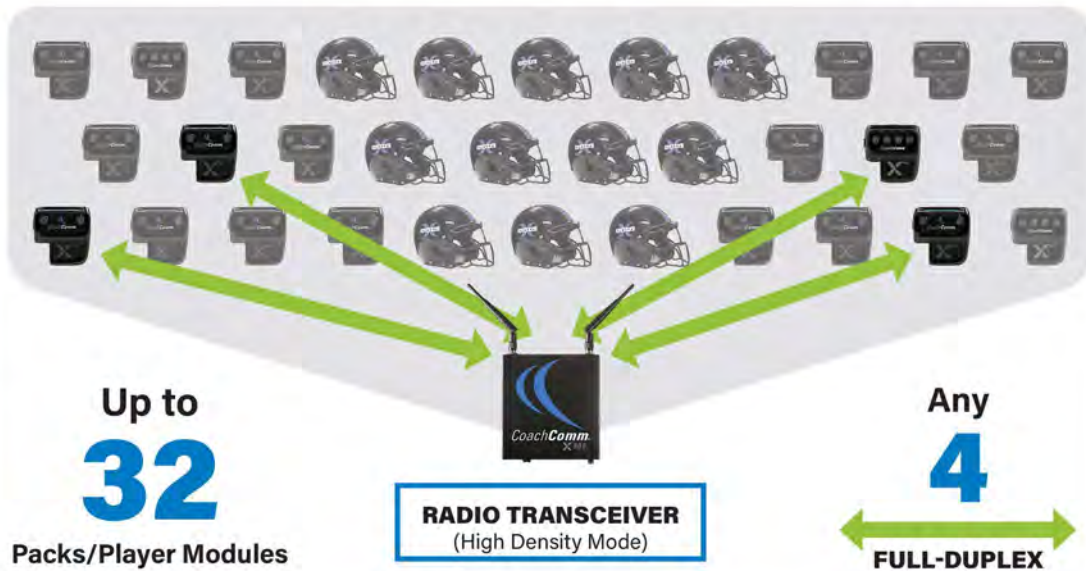

Changing Operational Mode

To choose High Density Mode for RTs in X-Ware, double-click on a Radio Transceiver in the Device Management list view to access its device view and view/edit its settings.

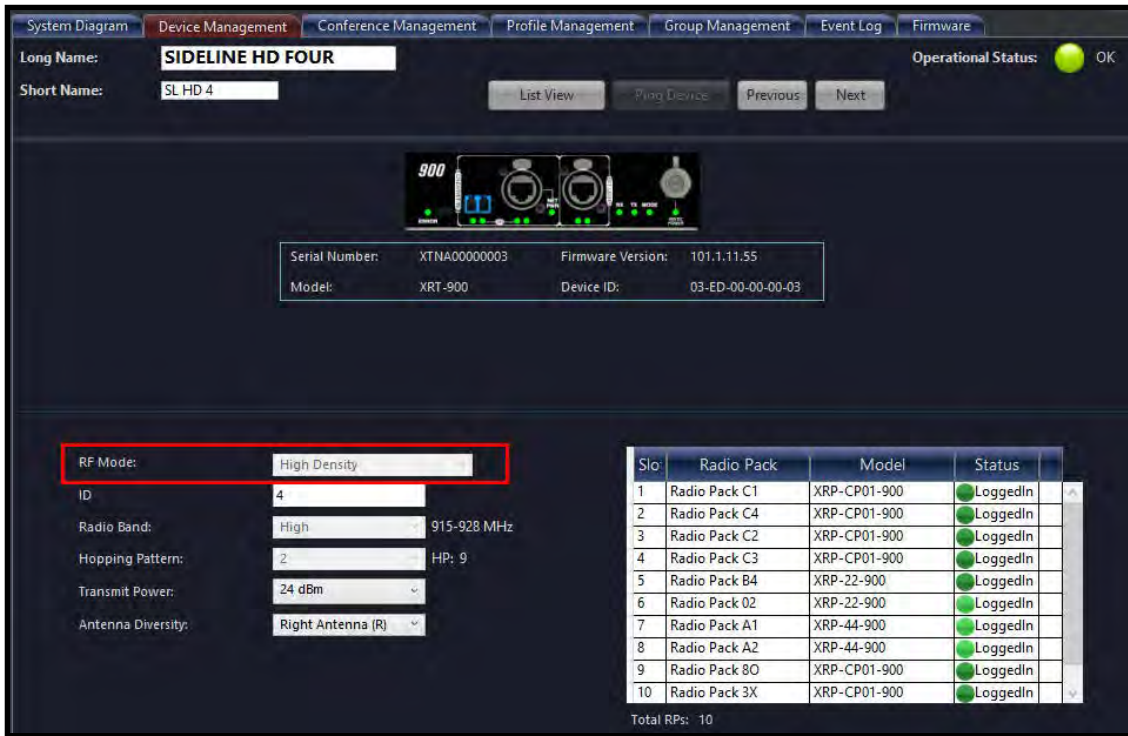

Figure 101: RT Operational Mode

To choose High Density Mode for RP Profiles in X-Ware, double-click on a Profile in the Profile Management list view to access its detail view and view/edit its settings. For more information on RP Profiles, see “Adding a Profile” on page 56.

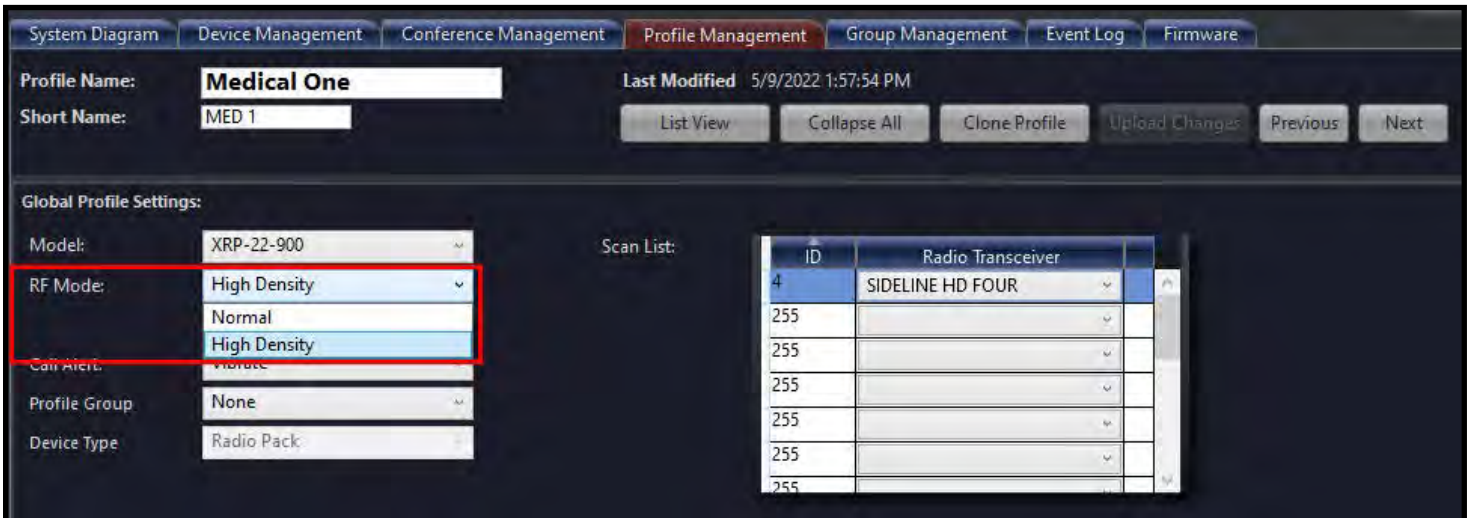

Figure 102: RP Profile Operational Mode

System Configuration File

X-System's Configuration File (CCF) contains everything about a system, including X-Net device locations, port assignments, conferences, and profiles. This file is used by the Control Unit, and it coordinates all device activity on the system. Only one configuration file can be live on a system at any given time; however, you can save multiple versions of configuration files locally or on a USB drive. These saved files have a ".ccf" file extension, which stands for "CoachComm Configuration File." CCFs can be edited offline using X-Ware on your PC and then uploaded to your Control Unit directly from X-Ware or via a portable USB drive at the front USB port of the CU. Instructions for Uploading a CCF are provided in the following sections.

Each X-System is pre-configured by CoachComm with the customer's desired settings. Saving, setup, and modifications of the configuration file are performed in X-Ware, if used. CoachComm's Customer Support staff is available to help with any advanced configuration needs during the season.

Saving a Configuration File

Changes to the configuration during operation will be saved at the Control Unit (CU). However, if you wish to save a copy of the configuration file for later use, follow these procedures:

1. Connect your computer to the CU. See "Connecting X-Ware to Your CU" on page 41 for more details on this process, if needed.
2. Make sure your CU is powered on. If you have not already done so, set the Home/Away status.
3. Launch X-Ware, then click the gear icon located at the top right of the home screen. This will launch X-Ware's Advanced Settings window. (See page 43 of this manual for more information about using X-Ware.)
4. If you wish to save your file to a USB Drive, insert one into your personal computer or laptop.

Note: Make sure the USB drive has enough space on it to save the file. 50 KB should be sufficient.

5. Go to **File** and click **Save File As...** and save your file to your USB drive or to a designated folder on your computer.

Note: The file name must be 8 characters or less! It is helpful to include your school and a date in the name when sending it to CoachComm for assistance. For example, AU_W9_18, TAMU8.30, etc.

Note: The X-System CU is currently compatible with FAT and FAT32 formatted USB thumb drives (up to 16 TB drive size). Some operating systems (e.g., Windows 10) promote NTFS format, but only allow FAT32 formatting up to 32 GB. For help with formatting larger USB thumb drives, contact CoachComm Customer Support at 1.800.749.2761.

6. Once the file has been saved, you can exit out of the software and eject the USB drive from the computer.

See "Uploading a Configuration File" on page 65 for instructions on uploading a saved file to your system. See "Opening a System Configuration File Offline" on page 54 for instructions on how to work with a saved configuration file.

Uploading a Configuration File

Uploading a Configuration File via X-Ware

Follow these procedures when uploading a previously saved configuration file to your system via X-Ware. See "Opening a System Configuration File Offline" on page 54 for instructions on how to work with a saved configuration file.

1. Connect your Antennas, make sure your Control Unit (CU) is powered on and has completed loading the current configuration file, select Home or Away, and open X-Ware. The system will be "Live" using the CU's current configuration file.

2. Open X-Ware Advanced Settings window by clicking on the Gears icon.
3. Save a backup copy of the current configuration file by selecting **Save File As...** from the File menu. A Windows directory will display where you can choose a file location and name for the saved backup file.
Important: Saving a backup copy of the current configuration file is helpful in case you need to revert back to it for any reason.
4. Select **Upload File...** from the File menu.
5. Follow the X-Ware prompts to complete the upload. While uploading, X-Ware will notify you of any configuration exceptions (for example, any RPs needing to be repaired).
6. During the upload, X-Ware will disconnect.
7. Acknowledge all X-Ware prompts, then reboot your X-System CUs when prompted by the CU LCD. Once rebooted, X-Ware will reconnect.

Loading a System Configuration File via USB Drive

Follow these procedures when uploading a previously saved configuration file to your system via USB Drive. See “Opening a System Configuration File Offline” on page 54 for instructions on how to work with a saved configuration file.

Important! Be sure you have saved a backup copy of your current configuration file prior to loading a new one, in case you need to revert back to it for any reason.

1. Make sure the Control Unit (CU) is powered on and has completed loading the current configuration file, then plug the USB drive into the front of the CU. An External USB Drive menu screen will display on the CU LCD.
2. Use the CU’s navigation buttons to scroll through the list of menu options on the CU’s LCD until **Upload System Configuration** is highlighted.

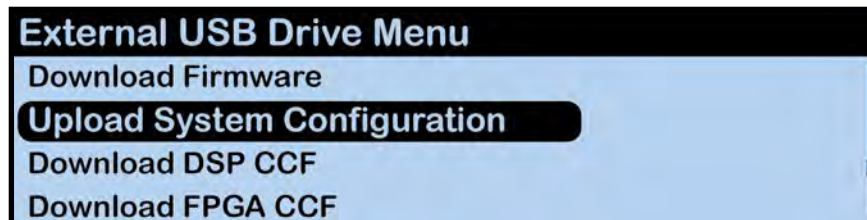

Figure 103: CU LCD Upload Configuration File Prompt

3. Press the CU’s enter button and scroll until you find the configuration file you wish to use, then press enter to select it.



Figure 104: CU LCD List of Available Configuration Files

- The CU screen will display a progress message while the new configuration file loads.

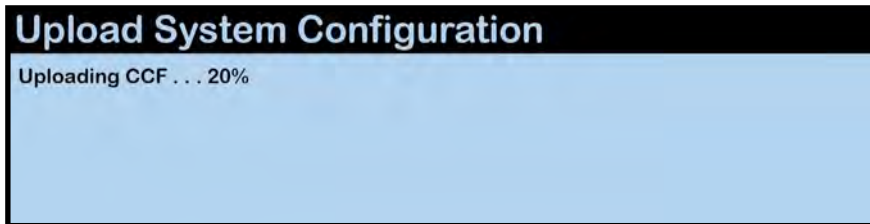

Figure 105: CU LCD: Sample CCF Upload In Progress Screen

- Once the configuration file has finished loading, the CU will display the following message: “Upload System Configuration. CCF Upload Complete.” along with a configuration file summary. A prompt will instruct you to “Please cycle power to Control Unit and any connected devices.” Reboot the CU.



Figure 106: CU LCD: Sample CCF Upload Completed Screen

- Select either **Home** or **Away** when prompted on the CU. Once the Home/Away prompt is cleared, the CCF load progress can be seen on the CU.



Figure 107: CU Home/Away Prompt and Progress Bar

- Wait until the CUs display the “CCF Loaded” message along with a configuration file summary. When the CCF load is complete, the home screen will display on the front of the CU(s) and you can proceed with operation.

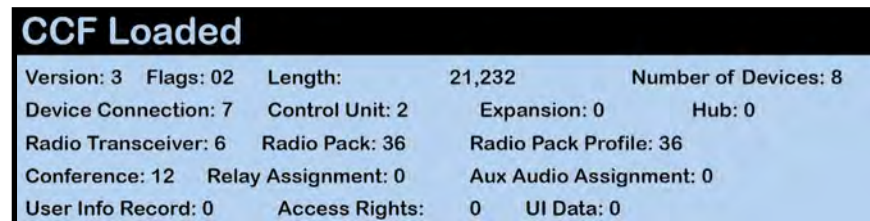

Figure 108: CCF Loaded Confirmation Screen

System Maintenance

Basic Maintenance

CoachComm recommends the following best practices when maintaining your X-System components.

1. If the system is exposed to rain, dry all parts of X-System carefully, including cables and connectors.
2. Always make sure that nuts and bolts are secure prior to and after operating.
3. Connect or disconnect cables by holding the connectors (not the sheath of the cable) and pressing the release button if applicable.
4. It is recommended that X-System be stored in a climate-controlled environment when not in use.
5. **Storage Temperature:** If a climate-controlled storage space is not available, X-System equipment can be stored in temperatures ranging from 5° to 130° F. However, when going from cold to warm environments, electronics can form condensation, which can cause damage to the electronic components. If storing your system in these types of conditions, wait for the equipment to acclimate to the ambient temperature before using.

Lithium-Polymer Battery Maintenance

Storage of your Lithium-Polymer Batteries

When stored, a battery gradually loses its overall charge time due to internal self-discharge, which may reduce its overall power. If storing batteries for two or more weeks, CoachComm highly recommends storing them at a 40–50% charge level, which generally minimizes any permanent power capacity loss. If storing CoachComm X-System Player Modules for more than a week, disconnect battery from rest of player module assembly.

Unused lithium-polymer batteries may enter into a deep discharge state due to internal self-discharge. Once a battery has gone into deep discharge, its onboard circuit protections inhibit the charger from initiating the charge cycle. If a battery does not accept a charge and the LED displays red in the charger, the battery may be in deep discharge. An attempt to revive the battery can be made by repeatedly inserting and removing it several times from the 5-Bay charger (CBT-5BAY-01).

Ambient temperature affects the rate at which lithium-polymer batteries degrade. Batteries also degrade and lose overall power capacity if stored (or used) at higher temperatures.

Proper Disposal of Old Lithium-Polymer Batteries

Batteries that appear swollen, deformed, or damaged, or that do not fit properly should never be used. Properly dispose of any batteries in this condition in accordance with the instructions provided by your local authorities. For more information and local drop-off sites, visit <https://www.call2recycle.org/>.

Battery Shipping Regulations

Rechargeable lithium-polymer batteries are subject to special U.S. and International regulations, particularly regarding transportation. The guidelines detailed in CoachComm's [Lithium-Polymer Battery Shipping Guidelines](#) document comply with updated International Air Transport Association (IATA), International Civil Aviation Organization (ICAO), and U.S. Department of Transportation (DOT) Dangerous and Hazardous Goods regulations.

Spare lithium batteries are not allowed in checked airline baggage. Be sure to follow all FAA, IATA, and airline rules and regulations when traveling with your X-System.

When shipping equipment to CoachComm that includes batteries, it is the shipper's responsibility to ensure that batteries are properly packaged, labeled, and shipped according to local and international guidelines. "Shipper" is defined as the person or school placing the equipment in the package and offering it to the carrier.

Troubleshooting Common Issues

Symptom/s	Potential Problem/s	Corrective Action/s
Noise/Static/Hum on System or on a Channel	Faulty ground plug	Move to another outlet, or apply ground isolation adapter to plug.
	Bad wired accessory such as Wired BeltPack, cable, or headset	Process of elimination: remove items on line in question one at a time until problem disappears.
Crosstalk	Bad wired accessory such as a Wired BeltPack, cable, or headset	Process of elimination: remove items on combined lines one at a time until crosstalk disappears.
Red LEDs on 5-Bay Charger	Ambient temperature too high to charge (safety mechanism)	Charge indoors or move chargers to a cooler location.

Product Support

CoachComm support and service personnel are ready to help you with any issues you may have. CoachComm offers product support from 8:00 a.m. to 5:00 p.m. (CST), Monday through Friday. Customers who annually renew their support plan have access to CoachComm's 24/7 after-hours support hotline as well. (Access this line by dialing our voice number and following the automated prompts to the After-Hours line. Leave a message there, and your call will be returned as soon as possible.) Our company website, www.coachcomm.com, offers supporting product documentation and live chat for help. All questions and/or requests for a Return Material Authorization (RMA) Number should be directed to the Customer Service department:

CoachComm Customer Service Department
Voice: 1.800.749.2761
Fax: 1.888.329.2658
Email: customer.service@coachcomm.com

Returning Equipment for Repair or Maintenance

Do not return any equipment directly to the factory without first obtaining a Return Material Authorization (RMA) Number. Obtaining a Return Material Authorization Number will ensure that your equipment is handled promptly.

All shipments of CoachComm products should be made via UPS, or the best available shipper, prepaid and insured. The equipment should be shipped in the original packing carton; if that is not available, use any suitable container that is rigid and of adequate size to surround the equipment with at least four inches of shock-absorbing material.

Battery Shipping Disclaimer: When shipping equipment to CoachComm that includes batteries, it is the shipper's responsibility to ensure that batteries are properly packaged, labeled, and shipped according to local and international guidelines. "Shipper" is defined as the person or school placing the equipment in the package and offering it to the carrier. Refer to CoachComm's [Lithium-Polymer Battery Shipping Guidelines document](#) on our website for more information.

All shipments should be sent to the following address and must include a Return Material Authorization Number:

CoachComm Customer Service Department
Attn: Return Material Authorization #
205 Technology Parkway
Auburn, AL 36830-0500

License Information

Radio Device License Information

Warning: Changes or modifications to this device not expressly approved by CoachComm could void the user's authority to operate the equipment.

1. FCC Notices

- 1.1. This device complies with Part 15 of the FCC Rules. Operation is subject to the following two conditions: (1) This device may not cause harmful interference, and (2) this device must accept any interference that may cause undesired operation.
- 1.2. This equipment has been tested and found to comply with the limits for a Class A digital device, pursuant to part 15 of the FCC rules. These limits are designed to provide reasonable protection against harmful interference when the equipment is operated in a commercial environment. This equipment generates, uses, and can radiate radio frequency energy and, if not installed and used in accordance with the instruction manual, may cause harmful interference to radio communications. Operation of this equipment in a residential area is likely to cause harmful interference in which case the user will be required to correct the interference at his own expense.

2. Canada, Industry Canada (IC) Notices

- 2.1. This Class A digital apparatus complies with Canadian ICES-003.

Cet appareil numérique de la classe A est conforme à la norme NMB-003 du Canada.

- 2.2. Under Industry Canada regulations, this radio transmitter may only operate using an antenna of a type and maximum (or lesser) gain approved for the transmitter by Industry Canada. To reduce potential radio interference to other users, the antenna type and its gain should be so chosen that the equivalent isotropically radiated power (e.i.r.p.) is not more than that necessary for successful communication.

Conformément à la réglementation d'Industrie Canada, le présent émetteur radio peut fonctionner avec une antenne d'un type et d'un gain maximal (ou inférieur) approuvé pour l'émetteur par Industrie Canada. Dans le but de réduire les risques de brouillage radioélectrique à l'intention des autres utilisateurs, il faut choisir le type d'antenne et son gain de sorte que la puissance isotrope rayonnée équivalente (p.i.r.e.) ne dépasse pas l'intensité nécessaire à l'établissement d'une communication satisfaisante.

- 2.3. This radio transmitter (FCCID: 2AX9C-CCT24 & 2AX9C-CCT900, IC: 30796-CCT24 & 30796-CCT900) has been approved by Industry Canada to operate with the antenna types listed below with the maximum permissible gain and required antenna impedance for each antenna type indicated. Antenna types not included in this list, having a gain greater than the maximum gain indicated for that type, are strictly prohibited for use with this device.

Le présent émetteur radio (FCCID: 2AX9C-CCT24 & 2AX9C-CCT900, IC: 30796-CCT24 & 30796-CCT900) a été approuvé par Industrie Canada pour fonctionner avec les types d'antenne énumérés ci-dessous et ayant un gain admissible maximal et l'impédance requise pour chaque type d'antenne. Les types d'antenne non inclus dans cette liste, ou dont le gain est supérieur au gain maximal indiqué, sont strictement interdits pour l'exploitation de l'émetteur.

- 2.4. This device complies with Industry Canada licence-exempt RSS standard(s). Operation is subject to the following two conditions: (1) this device may not cause interference, and (2) this device must accept any interference, including interference that may cause undesired operation of the device.

Le présent appareil est conforme aux CNR d'Industrie Canada applicables aux appareils radio exempts de licence. L'exploitation est autorisée aux deux conditions suivantes : (1) l'appareil ne doit pas produire de brouillage, et (2) l'utilisateur de l'appareil doit accepter tout brouillage radioélectrique subi, même si le brouillage est susceptible d'en compromettre le fonctionnement.

RF-Exposure Statements

Radio Packs

X-System Radio Packs have been designed to be worn and used in close proximity to the human body—what the FCC calls a “portable” use.

This equipment complies with FCC radiation exposure limits set forth for an uncontrolled environment. This equipment is in direct contact with the body of the user under normal operating conditions. This transmitter must not be co-located or operating in conjunction with any other antenna or transmitter.

Radio Transceiver/Antenna

The X-System Radio Transceiver/Antenna has been designed for use as what the FCC calls a “mobile” device.

This equipment complies with FCC radiation exposure limits set forth for an uncontrolled environment. This equipment should be installed and operated with minimum distance 20 cm (7.87 in.) between the radiator and your body. This transmitter must not be co-located or operating in conjunction with any other antenna or transmitter.

Non-Radio-Device License Information

Warning: Changes or modifications to this device not expressly approved by CoachComm could void the user's authority to operate the equipment.

1. FCC Notices

- 1.1. This device complies with Part 15 of the FCC Rules. Operation is subject to the following two conditions: (1) This device may not cause harmful interference, and (2) this device must accept any interference that may cause undesired operation.
- 1.2. This equipment has been tested and found to comply with the limits for a Class A digital device, pursuant to part 15 of the FCC rules. These limits are designed to provide reasonable protection against harmful interference when the equipment is operated in a commercial environment. This equipment generates, uses, and can radiate radio frequency energy and, if not installed and used in accordance with the instruction manual, may cause harmful interference to radio communications. Operation of this equipment in a residential area is likely to cause harmful interference in which case the user will be required to correct the interference at his own expense.

1. Canada, Industry Canada (IC) Notices

- 1.1. This Class A digital apparatus meets all requirements of the Canadian Interference Causing Equipment Regulations.

Cet appareillage numérique de la classe A répond à toutes les exigences de l'interférence canadienne causant des règlements d'équipement.

X-Ware™ End User License Agreement (EULA)

This End-User License Agreement (the “EULA”) is a legal agreement between you (the “Licensee”), an individual, and CoachComm, LLC (the “Company”), the author of X-Ware (the “Software”), including the deliverables provided pursuant to this EULA, which may include data files, scripts, programs, associated media, printed materials, “online” or electronic documentation.

By installing, copying, or otherwise using the Software, Licensee agrees to be bound by the terms and conditions set forth in this EULA. If Licensee does not agree to the terms and conditions set forth in this EULA, then Licensee may not download, install, or use Software.

Please read this EULA agreement carefully before completing the installation process and using X-Ware. It provides a license to use X-Ware and contains warranty information and liability disclaimers.

This EULA agreement shall apply only to the Software supplied by CoachComm, LLC herewith regardless of whether other software is referred to or described herein. The terms also apply to any CoachComm, LLC updates, supplements, Internet-based services, and support services for the Software, unless other terms accompany those items on delivery. If so, those terms apply.

If you are entering into this EULA agreement on behalf of a company or other legal entity, you represent that you have the authority to bind such entity and its affiliates to these terms and conditions. If you do not have such authority or if you do not agree with the terms and conditions of this EULA agreement, do not install or use the Software, and you must not accept this EULA agreement.

License Grant

- A. **Software Product License.** Subject to the terms of this EULA, Company hereby grants to Licensee a royalty-free, non-exclusive, non-transferable license to possess and to use a copy of the Software. Software is being distributed by Company. Licensee is not allowed to make a charge for distributing this Software, either for profit or merely to recover media and distribution costs.
- B. **Installation and Use.** Licensee may install and use an unlimited number of copies of Software on a shared computer or concurrently on different computers, and make multiple back-up copies of Software, solely for Licensee’s use within Licensee’s business or personal use.

Description of Rights and Limitations

- A. **Limitations.** The user shall use X-Ware strictly in accordance with the terms of the related Agreements and shall not (a) decompile, reverse engineer, disassemble, attempt to derive the source code of, or decrypt X-Ware; (b) make any modification, adaptation, improvement, enhancement, translation or derivative work from X-Ware; (c) violate any applicable laws, rules or regulations in connection with the user’s access or use of X-Ware; (d) reproduce, copy, distribute resell, or otherwise use the software for any commercial purpose; (e) use any other proprietary information interfaces of CoachComm or other intellectual property of CoachComm in the design, development, manufacture, licensing, or distribution of any applications or devices for use with X-Ware.
- B. **Separation of Components.** Software is licensed as a single product. Its components may not be separated for use on more than one computer.
- C. **Software Transfer.** Licensee may permanently transfer all rights under the EULA, provided recipient agrees to the terms of this EULA.

Intellectual Property

All rights, title, interest, and copyrights in and to the Software, including but not limited to all images, photographs, animations, video, audio, music, text, data, computer code, algorithms, and information, are owned by Company. The Software is protected by all applicable copyright laws and international treaties. Therefore, Licensee is required to treat Software like any other copyrighted material, except as otherwise provided for in this EULA.

- A. **Infringement Acknowledgement.** The user and CoachComm acknowledge and agree that, in the event of a third party claim that X-Ware or the user's possession or use of X-Ware infringes any third party's intellectual property rights, the user (and not CoachComm) will be responsible for the investigation, defense, settlement, and discharge of any such claim of intellectual property infringement. You will, however, promptly notify CoachComm in writing of such a claim.

Modifications to X-Ware

CoachComm reserves the right to modify, suspend, or discontinue, temporarily or permanently, X-Ware or any service to which it connects, with or without notice and without liability to the user.

Termination

CoachComm may, in its sole and absolute discretion, at any time and for any reason, suspend or terminate this License and the rights afforded to the user hereunder with or without prior notice. Furthermore, if the user fails to comply with the terms and conditions of this License, then this License and any rights afforded to the user hereunder shall terminate automatically, without any notice or other action by CoachComm. Upon termination of this License, the user shall cease all use of X-Ware and uninstall X-Ware.

Integration

Both parties agree that this EULA is the complete and exclusive statement of the mutual understanding of the parties and supersedes and cancels all previous written and oral agreements and communications relating to the subject matter of this EULA.

Jurisdiction

This EULA shall be deemed to have been made in, and shall be construed pursuant to the laws of the State of Alabama, without regard to conflicts of laws provisions thereof. Any legal action or proceeding relating to this EULA shall be brought exclusively in courts located in Auburn, Alabama, and each party consents to the jurisdiction thereof. The prevailing party in any action to enforce this EULA shall be entitled to recover costs and expenses including, without limitation, attorneys' fees. This EULA is made within the exclusive jurisdiction of the United States, and its jurisdiction shall supersede any other jurisdiction of either party's election.

Non-Transferable

This EULA is not assignable or transferable by Licensee without the prior written consent of Company; any attempt to do so shall be void. Any notice, report, approval or consent required or permitted hereunder shall be in writing and will be deemed to have been duly given if delivered personally or mailed by first-class, registered or certified mail, postage prepaid to the respective addresses of the parties as set forth herein (or such other address as a party may designate by ten (10) days' notice.

Severability

No failure to exercise, and no delay in exercising, on the part of either party, any privilege, any power or any rights hereunder will operate as a waiver thereof, nor will any single or partial exercise of any right or power hereunder preclude further exercise of any other right hereunder. If any provision of this EULA shall be adjudged by any court of competent jurisdiction to be unenforceable or invalid, that provision shall be limited or eliminated to the minimum extent necessary so that this EULA shall otherwise remain in full force and effect and enforceable.

Disclaimer of Warranties

The user acknowledges and agrees that X-Ware is provided on an “as is” and “as available” basis, and that the user’s use of or reliance upon the application and any third party content and services accessed thereby is at your sole risk and discretion. CoachComm and its affiliates, partners, suppliers, and licensors hereby disclaim any and all representations, warranties, and guaranties regarding X-Ware and third party content and services, whether express, implied, or statutory, and including without limitation, the implied warranties of merchantability, fitness for a particular purpose, and non-infringement. Furthermore, CoachComm and its affiliates, partners, suppliers, and licensors make no warranty that i) the application or third party content and services will meet your requirements; ii) X-Ware or third party content and services will be uninterrupted, accurate, reliable, timely, secure, or error-free; iii) the quality of any products, services, information, or other material accessed or obtained by you through X-Ware will be as represented or meet your expectations; or iv) any errors in X-Ware or third party content and services will be corrected.

Limitation of Liability

Company shall not be liable to Licensee, or any other person or entity claiming through Licensee any loss of profits, income, savings, or any other consequential, incidental, special, punitive, direct or indirect damage, whether arising in contract, tort, warranty, or otherwise. Even if Company has been advised of the possibility of such damages. These limitations shall apply regardless of the essential purpose of any limited remedy. Under no circumstances shall Company’s aggregate liability to Licensee, or any other person or entity claiming through Licensee, exceed the financial amount actually paid by Licensee to Company for the Software.

Warranty Information

Limited Warranty

X-System™ products are warranted to be free from defects in materials and workmanship for a period of one year from the date of sale to the end user.

CoachComm Cobalt™, Tempest®, and CoachComm Connex® systems carry a two-year product warranty.

The purchase of a maintenance and support plan is not a condition of coverage under this limited warranty; however, purchasing a plan does extend a product's warranty for an additional year.

The sole obligation of CoachComm, LLC during the warranty period is to provide, without charge, parts and labor necessary to remedy covered defects appearing in products returned prepaid to CoachComm, LLC. This warranty does not cover any defect, malfunction, or failure caused by circumstances beyond the control of CoachComm, LLC, including but not limited to negligent operation, abuse, accident, failure to follow instructions in this Operating Guide, product misuse, defective or improper associated equipment, product alteration, modification and/or repair not authorized by CoachComm, LLC or shipping damage. Products with their serial numbers removed or effaced are not covered by this warranty.

This limited warranty is the sole and exclusive warranty given with respect to CoachComm, LLC products. It is the responsibility of the user to determine before purchase that this product is suitable for the user's intended purpose.

THE PROVIDED WARRANTIES ARE EXCLUSIVE AND TAKE THE PLACE OF ALL OTHER EXPRESS OR IMPLIED WARRANTIES OR CONDITIONS INCLUDING BUT NOT LIMITED TO WARRANTIES OR CONDITIONS OF MERCHANTABILITY, SATISFACTORY QUALITY, INFRINGEMENT AND FITNESS FOR A PARTICULAR PURPOSE, ALL OF WHICH ARE DISCLAIMED.

Parts Limited Warranty

Replacement parts for CoachComm, LLC products are warranted to be free from defects in materials and workmanship for 120 days from the date of sale to the end user.

This warranty does not cover any defect, malfunction, or failure caused by circumstances beyond the control of CoachComm, LLC, including but not limited to negligent operation, abuse, accident, failure to follow instructions in the Operating Manual, defective or improper associated equipment, attempts at modification and/or repair not authorized by CoachComm, LLC, and shipping damage. Any damage done to a replacement part during its installation voids the warranty of the replacement part.

This limited warranty is the sole and exclusive express warranty given with respect to CoachComm, LLC products. It is the responsibility of the user to determine before purchase that this product is suitable for the user's intended purpose. ANY AND ALL IMPLIED WARRANTIES, INCLUDING THE IMPLIED WARRANTY OF MERCHANTABILITY, ARE LIMITED TO THE DURATION OF THIS EXPRESS LIMITED WARRANTY. NEITHER COACHCOMM, LLC NOR ANY AUTHORIZED RESELLER WHO SELLS COACHCOMM PRODUCTS IS LIABLE FOR INCIDENTAL OR CONSEQUENTIAL DAMAGES OF ANY KIND.

Battery Warranty

CoachComm provides a one-year warranty for all CoachComm branded lithium-polymer rechargeable batteries (one year from the date of sale to and purchase by the end user). The warranty period is based upon the expectation that the battery will deliver 80% of its initial capacity after 300 cycles at typical power loads. Lithium-polymer batteries will continue to operate below 80% capacity threshold; however, the capacity (run time) delivered between charges will continue to decrease. Apart from this warranty, batteries are also covered as part of the customer's annual maintenance plan (where applicable).

Glossary

Conference - A grouping of audio entities. Radio Packs may subscribe to one or more conferences.

Mic Gain - Increase in the power of the signal from the microphone

Mic Type - Either electret or dynamic, determined by user selection or system auto-detection

Noise Gate - Dynamic processor that suppresses unwanted noise present when the audio signal is at a low level

Profile - A Radio Pack profile assigns functionality to a Radio Pack's local controls, knobs, and buttons as well as what conferences they subscribe to.

Sidetone - The user's own voice folded back into the user's ear. This adjustment allows for a user to hear more or less of his/her own voice in his/her headset. If sidetone is turned down, the user can still hear other users but he/she cannot hear his/her own voice. If the sidetone is turned up too far, the user may cause "feedback" or squealing on his/her intercom line.

Radio Transceiver - (also known as "Antenna") A device used to remotely locate a radio and its Antenna to provide better and more expanded coverage area for wireless communication.

Specifications

***Notice About Specifications:** While CoachComm makes every attempt to maintain the accuracy of the information contained in this manual, this information is subject to change without notice. Please check our website for the latest system specifications and certifications.

Control Unit Specifications

Control Unit Specification	XCU-44
Hardwired Intercom Audio Channels (per CU)	8 (four 2-wire and four 4-wire)
Active Radio Packs (Normal Mode) (per CU)	12
USB Ports	(1) USB Type A; (1) Micro USB
Front Panel LCD Display	512 × 128 resolution
Stage Announce and GPO Closures	5 Relays via DA-15
X-Net Ports (supports 2 connections)	(2) RJ-45 for copper; (1) duplex LC for Single Mode Fiber
Sync In Ports (supports 1 connection)	(1) RJ-45 for copper; (1) duplex LC for Single Mode Fiber
2-Wire Intercom Connection	4 channels via XLR 3F with XLR 3M loop (4 ports)
2-Wire Compatibility	Clear-Com, RTS, and AudioCom (Balanced)
4-Wire Intercom Connection	4 ports via RJ-45
Stage Announce Output	XLR 3M, nominal 12 dBu into 600 ohms, balanced, transformer isolated
AUX IN	1/4" (6.35 mm) 3 conductor jack, 17.5 dBu max in, balanced, transformer isolated
AUX OUT	1/4" (6.35 mm) 3 conductor jack, 12 dBu into 600 ohms, balanced, transformer isolated
LAN Port	(1) RJ-45
Power Input/Connector	100–240V ~ 50–60 Hz, 1.8A
Dimensions	1 RU, 19 in. × 1.73in. × 11.68 in. (48.3 cm × 4.4 cm × 29.7 cm) metal enclosure
Weight	6.5 lbs (2.9 kg)
Operating Environment	-20° to 50° C (-4° to 122° F); 10% to 90% Humidity.
Maximum Line Length	Copper 330 ft. (100 m); Fiber 32,800 ft. (10,000 m)
Maximum Altitude	6,562 ft. (2,000 m)
RoHS Compliant	Yes

Radio Transceiver Specifications

Radio Transceiver Specification	XRT-ANT-900
RF Frequency (MHz)	902–928 MHz
RF Scheme	FHSS with TDMA
Effective Radiated Power	400 mW (+26dBm)
Receiver Sensitivity	-100 dBm at 10 ⁻⁵ BER
Radio Certification	FCCID: 2AX9C-CCT900 and IC: 30796-CCT900
Transmission Range	650 ft. (200 m) under typical conditions; 1950 ft. (600 m) line of sight (Note: Functional range depends on many variables, including RF signal absorption, reflection, and external interference.)
No. of Radio Packs Supported (when Antenna in Normal Mode)	6
Supplied Antenna	+5dBi Directional (integrated patch)
X-NET IN Port (supports 1 connection)	(1) RJ-45
RT LOOP Port	(1) RJ-45
Maximum Line Length	Copper 330 ft. (100 m)
Network Power	X-Net RJ-45 only
Dimensions (inches)	6.30 in. × 7.74 in. × 1.81 in. (16 cm × 19.7 cm × 4.6 cm)
Weight	1.25 lbs (567 g)
Operating Environment	-20° to 50° C (-4° to 122° F); 10% to 90% Humidity
Maximum Altitude	6,562 ft. (2,000 m)
RoHS Compliant	Yes

Radio Pack Specifications

Specification	XRP-13-900	XRP-13-2400
RF Frequency (MHz)	902–928 MHz	2400–2483 MHz
RF Scheme	FHSS with TDMA	
Effective Radiated Power	400 mW (+26 dBm)	100 mW (+20 dBm)
Receiver Sensitivity	-100 dBm at 10 ⁻⁵ BER	
Radio Certification	FCCID: 2AX9C-CCT900 and IC: 30796-CCT900	FCCID: 2AX9C-CCT24 and IC: 30796-CCT24
Transmission Range	650 ft. (200 m) under typical conditions; 1950 ft. (600 m) line of sight (Note: Functional range depends on many variables, including RF signal absorption, reflection, and external interference.)	500 ft. (150 m) under typical conditions; 1500 ft. (450 m) line of sight (Note: Functional range depends on many variables, including RF signal absorption, reflection, and external interference.)
Audio Dynamic Range	Greater than 90 dB	
Audio Frequency Response	150 Hz–7 kHz	
Conferences	3	
Simultaneous Listen Paths	1	
Volume Knobs	1	
Talk Buttons	1	
Headset Connector	4-pin male XLR	
USB Port	(1) Micro USB	
Microphone Type	Auto Detect or Manual Select; Dynamic or Electret	
LCD Display	280 × 64 resolution	
Antenna (internal)	(2) 2dBi Dipole	
Battery Life, Rechargeable Lithium-Polymer	Greater than 9 hours	Greater than 10 hours
Charging Power Supply	Micro USB; 6W AC wall adapter	
Charge time for Lithium-Polymer Battery	Under 3 hours	
Optional Power	3 Standard AA alkaline batteries	
Battery Life, Alkaline batteries	Approximately 4.5 hours	Approximately 5 hours
Dimensions (inches)	4.5 in. × 4.57 in. × 2.31 in. (11.4 cm × 11.6 cm × 5.9 cm)	
Weight (with Lithium-Polymer battery)	13 oz. (910 g)	
Material	Polycarbonate substrate with thermoplastic elastomer overmold	
Operating Environment	-20° to 50° C (-4° to 122° F); 10% to 90% Humidity. RP Power Adapter is 0 to 40° C (32° to 104° F).	
Maximum Altitude	6,562 ft. (2,000 m)	
RoHS Compliant	Yes	
IP65 Rating	Yes	

Specification	XRP-22-900	XRP-22-2400
RF Frequency (MHz)	902–928 MHz	2400–2483 MHz
RF Scheme	FHSS with TDMA	
Effective Radiated Power	400 mW (+26 dBm)	100 mW (+20 dBm)
Receiver Sensitivity	-100 dBm at 10 ⁻⁵ BER	
Radio Certification	FCCID: 2AX9C-CCT900 and IC: 30796-CCT900	FCCID: 2AX9C-CCT24 and IC: 30796-CCT24
Transmission Range	650 ft. (200 m) under typical conditions; 1950 ft. (600 m) line of sight (Note: Functional range depends on many variables, including RF signal absorption, reflection, and external interference.)	500 ft. (150 m) under typical conditions; 1500 ft. (450 m) line of sight (Note: Functional range depends on many variables, including RF signal absorption, reflection, and external interference.)
Audio Dynamic Range	Greater than 90 dB	
Audio Frequency Response	150 Hz–7 kHz	
Conferences	2	
Simultaneous Listen Paths	True Dual Listen	
Volume Knobs	2	
Talk Buttons	2	
Headset Connector	4-pin male XLR	
USB Port	(1) Micro USB	
Microphone Type	Auto Detect or Manual Select; Dynamic or Electret	
LCD Display	280 × 64 resolution	
Antenna (internal)	(2) 2dBi Dipole	
Battery Life, Rechargeable Lithium-Polymer	Greater than 9 hours	Greater than 10 hours
Charging Power Supply	Micro USB; 6W AC wall adapter	
Charge time for Lithium-Polymer Battery	Under 3 hours	
Optional Power	3 Standard AA alkaline batteries	
Battery Life, Alkaline batteries	Approximately 4.5 hours	Approximately 5 hours
Dimensions (inches)	4.5 in. × 4.57 in. × 2.31 in. (11.4 cm × 11.6 cm × 5.9 cm)	
Weight (with Lithium-Polymer battery)	13 oz. (910 g)	
Material	Polycarbonate substrate with thermoplastic elastomer overmold	
Operating Environment	-20° to 50° C (-4° to 122° F); 10% to 90% Humidity. RP Power Adapter is 0 to 40° C (32° to 104° F).	
Maximum Altitude	6,562 ft. (2,000 m)	
RoHS Compliant	Yes	
IP65 Rating	Yes	

Specification	XRP-44-900	XRP-44-2400
RF Frequency (MHz)	902–928 MHz	2400–2483 MHz
RF Scheme	FHSS with TDMA	
Effective Radiated Power	400 mW (+26 dBm)	100 mW (+20 dBm)
Receiver Sensitivity	-100 dBm at 10 ⁻⁵ BER	
Radio Certification	FCCID: 2AX9C-CCT900 and IC: 30796-CCT900	FCCID: 2AX9C-CCT24 and IC: 30796-CCT24
Transmission Range	650 ft. (200 m) under typical conditions; 1950 ft. (600 m) line of sight (Note: Functional range depends on many variables, including RF signal absorption, reflection, and external interference.)	500 ft. (150 m) under typical conditions; 1500 ft. (450 m) line of sight (Note: Functional range depends on many variables, including RF signal absorption, reflection, and external interference.)
Audio Dynamic Range	Greater than 90 dB	
Audio Frequency Response	150 Hz–7 kHz	
Conferences	4	
Simultaneous Listen Paths	True Quad Listen	
Volume Knobs	4	
Talk Buttons	4	
Headset Connector	4-pin male XLR	
USB Port	(1) Micro USB	
Microphone Type	Auto Detect or Manual Select; Dynamic or Electret	
LCD Display	280 × 64 resolution	
Antenna (internal)	(2) 2dBi Dipole	
Battery Life, Rechargeable Lithium-Polymer	Greater than 9 hours	Greater than 10 hours
Charging Power Supply	Micro USB; 6W AC wall adapter	
Charge time for Lithium-Polymer Battery	Under 3 hours	
Optional Power	3 Standard AA alkaline batteries	
Battery Life, Alkaline batteries	Approximately 4.5 hours	Approximately 5 hours
Dimensions (inches)	4.5 in. × 4.57 in. × 2.31 in. (11.4 cm × 11.6 cm × 5.9 cm)	
Weight (with Lithium-Polymer battery)	13 oz. (910 g)	
Material	Polycarbonate substrate with thermoplastic elastomer overmold	
Operating Environment	-20° to 50° C (-4° to 122° F); 10% to 90% Humidity. RP Power Adapter is 0 to 40° C (32° to 104° F).	
Maximum Altitude	6,562 ft. (2,000 m)	
RoHS Compliant	Yes	
IP65 Rating	Yes	

Appendix A: CoachComm X-System Coach to Player Communication

The Player-worn Radio Pack Module (XRP-CP01-900) or new Mini Module (XRP-CP01M-900) can be added as an upgrade package to the X-System line that will allow for coaches to communicate with players either in a practice or game day environment. Its small size, robust housing, and simple interface allow it to be placed where needed. Integration into the X-System is seamless as software connectivity will allow for full control and routing of audio from coaches to players as needed.

Note: Products and software associated with CoachComm X-System Player and Referee Cutoff are only functional with the CoachComm X-System Player upgrade package.



Images not to scale.



Figure 109: CoachComm X-System Player Block Diagram (Single Wirelless Referee Interrupt Configuration)

Important Safety Information



WARNING: To prevent SERIOUS INJURY or DEATH, ALWAYS contact the helmet manufacturer for the approved device placement locations for the Radio Pack and its accessories. These may vary between helmet models and between helmet manufacturers.

- » ONLY use with NOCSAE compliant helmets.
- » ONLY use attachments or accessories specifically made for or approved by CoachComm.
- » ALWAYS refer all Radio Pack service to qualified CoachComm service personnel. There are no user serviceable parts inside the Radio Pack.
- » Before installing the Radio Pack and Speaker Assembly in a helmet, turn the volume to its lowest level. Place the Radio Pack and Speaker Assembly into the helmet following the recommendations of the helmet manufacturer for the specific helmet model.



CAUTION: HEARING LOSS HAZARD. To prevent possible permanent hearing loss, ALWAYS set the volume as low as possible depending on the ambient noise at practice or at a game.

- » DO NOT use Radio Pack if it emits any unusual loud noise. Turn Radio Pack off and contact CoachComm Customer Service.
- » Permanent hearing loss may result from exposure to high volumes or other loud noises.



WARNING: FIRE and EXPLOSION HAZARDS. Batteries may explode, may catch fire or cause chemical burns if damaged. To prevent SERIOUS INJURY or DEATH:

- » ALWAYS inspect batteries before use.
- » NEVER use batteries that appear swollen, deformed or damaged, feel hot or emit an unusual smell.
- » DO NOT allow batteries to overheat (reach temperatures of above 140 degrees Fahrenheit (60 degrees Celsius)). Keep batteries out of direct sunlight and away from other heat sources, including open flames.
- » REMOVE helmet immediately if you experience a warming sensation or loss of audio.
- » CoachComm recommends keeping a Class-D fire extinguisher available when charging lithium-polymer batteries. The chemicals inside lithium-polymer batteries are highly flammable.
- » ONLY use batteries approved for use with the Radio Pack. Contact CoachComm for assistance. Use of other batteries may present a risk of fire or explosion and the warranty will be terminated.
- » NEVER leave the batteries unattended while charging. Immediately unplug unit if battery begins to swell or emit smoke while charging. If battery bursts or chemicals begin to leak out of battery housing, the chemicals will react with the air and may result in a fire.
- » NEVER use a damaged charger.



CAUTION: California Prop 65

- » Lithium-ion batteries and products that contain lithium-ion batteries can expose you to chemicals including cobalt lithium nickel oxide, chromium and nickel, which are known to the State of California to cause cancer and birth defects or other reproductive harm. For more information, go to www.P65Warnings.ca.gov

CoachComm X-System Player Module

Components

- A. Coach/Player Radio Pack Module
- B. USB-C Charging/Pairing Port
- C. Speaker Assembly
- D. Rechargeable (LiPoly) Battery



Figure 110: CoachComm X-System Player



Figure 111: CoachComm X-System Player Mini

LED Power and Status Indicators

Indicator	State	Description	Details
Status	Green	Linked	Device is actively logged into a Radio Transceiver.
	Flashing Green	Searching for RT	Device is searching for a Radio Transceiver.
	Red	Unpaired	Device is not paired to a Control Unit. No profile found.
	Flashing Red	Error	Device is in an error state. Please contact CoachComm support.
	Flashing Amber	Pairing Complete	Device was successfully paired to a Control Unit.
	Red/Green Flashing	Updating	Device is receiving a firmware update or a profile update.
Power	Green	Full Battery	Battery charging is complete (while plugged in) or the battery is more than 50% full (while on battery power).
	Flashing Green	Charging	Battery is actively charging.
	Red	USB Power	Device powered by USB; no battery is detected.
	Flashing Red	Low Battery	Low Battery. Less than 15 minutes of run-time remaining.
	Amber	< 50% Battery	Battery has less than 50% life remaining.
	Flashing Amber	< 25% Battery	Battery has less than 25% life remaining.
	Flash every 30sec	Sleep	Device is in low power mode. Shake for 3 seconds to turn on.

CoachComm X-System Player Setup

Contact CoachComm Customer Service for assistance setting up CoachComm X-System Player modules with X-System.

Adding a Player Conference

See “Adding a Conference” on page 55 for information on how to add a conference in X-Ware.

1. Create and name a new player conference.
2. CoachComm recommends enabling High Density mode if a large number of player modules will be paired to the X-System.

PLAYER D	PLAY D	<input checked="" type="checkbox"/>	Call	Mic Kill
PLAYER O	PLAY O	<input checked="" type="checkbox"/>	Call	Mic Kill

Figure 112: Player Conference Examples

Coach Profile Modifications

Assign the player conference to a Talk button on the RP Profile and/or a function button. See “Adding a Profile” on page 56 and “Editing or Cloning Profiles” on page 57 for information on how to add and edit a profile in X-Ware.

Note: Only XRP-13s support coach to player communications. XRP-22 and XRP-44 do not support coach to player communication using the function buttons, but the Talk buttons can be assigned to a player conference. The function button options below will not be available when the conference is assigned a Talk button.

The screenshot shows the 'Profile Management' interface for 'Coach Jackson'. The interface includes tabs for System Diagram, Device Management, Conference Management, Profile Management, Group Management, Event Log, and Firmware. The profile name is 'Coach Jackson' and the short name is 'JACKSON'. The last modified date is 6/14/2022 2:06:56 PM. There are buttons for List View, Collapse All, Clone Profile, Upload Changes, Previous, and Next.

Three conference settings are visible:

- Conference A:** Conf: OFFENSE, Button Mode: AlwaysOn. Min Vol: 10, Max Vol: 20.
- Conference B:** Conf: PLAYER O, Button Mode: AlwaysOn. Min Vol: 10, Max Vol: 20. This row is highlighted with a red box.
- Conference C:** Conf: SPECIAL TEAMS, Button Mode: Momentary, Audio Overlay: Off. Min Vol: 10, Max Vol: 20.

Two function button settings are visible:

- Function Button 1:** Function: C2PMix, Button Mode: Disable. Conference Assignment: PLAYER O. This row is highlighted with a red box.
- Function Button 2:** Function: None, Button Mode: Disable.

Figure 113: Coach RP Profile Player Conferences Assigned to Talk Button and Function Button

Follow the steps below to assign the player conference to a function button:

1. Under Function, select one of three coach to player options for the function button.



Figure 114: Coach RP Profile Function Options

Coach/Player Isolated Talk: Only coaches and player modules on the player conference can hear the speaker when the function button is pressed, and the speaker can hear other RPs from the active conference at the RP's volume level.

Coach/Player Mix: The speaker's audio is sent to both the player and active conferences simultaneously while still listening to the active conference at the RP's volume level.

Coach/Player Switch: Only coaches and player modules on the player conference can hear the speaker when the function button is pressed, and the speaker can only hear other RPs on the player conference at the RP's volume level.

2. The Conference Assignment Selection will appear once the Function is chosen. Select a player conference.
3. Select a Button Mode for the function button (Always On is not available as a Button Mode for coach to player communications).

Adding a Player Profile

See "Adding a Profile" on page 56 for information on how to add a profile in X-Ware.

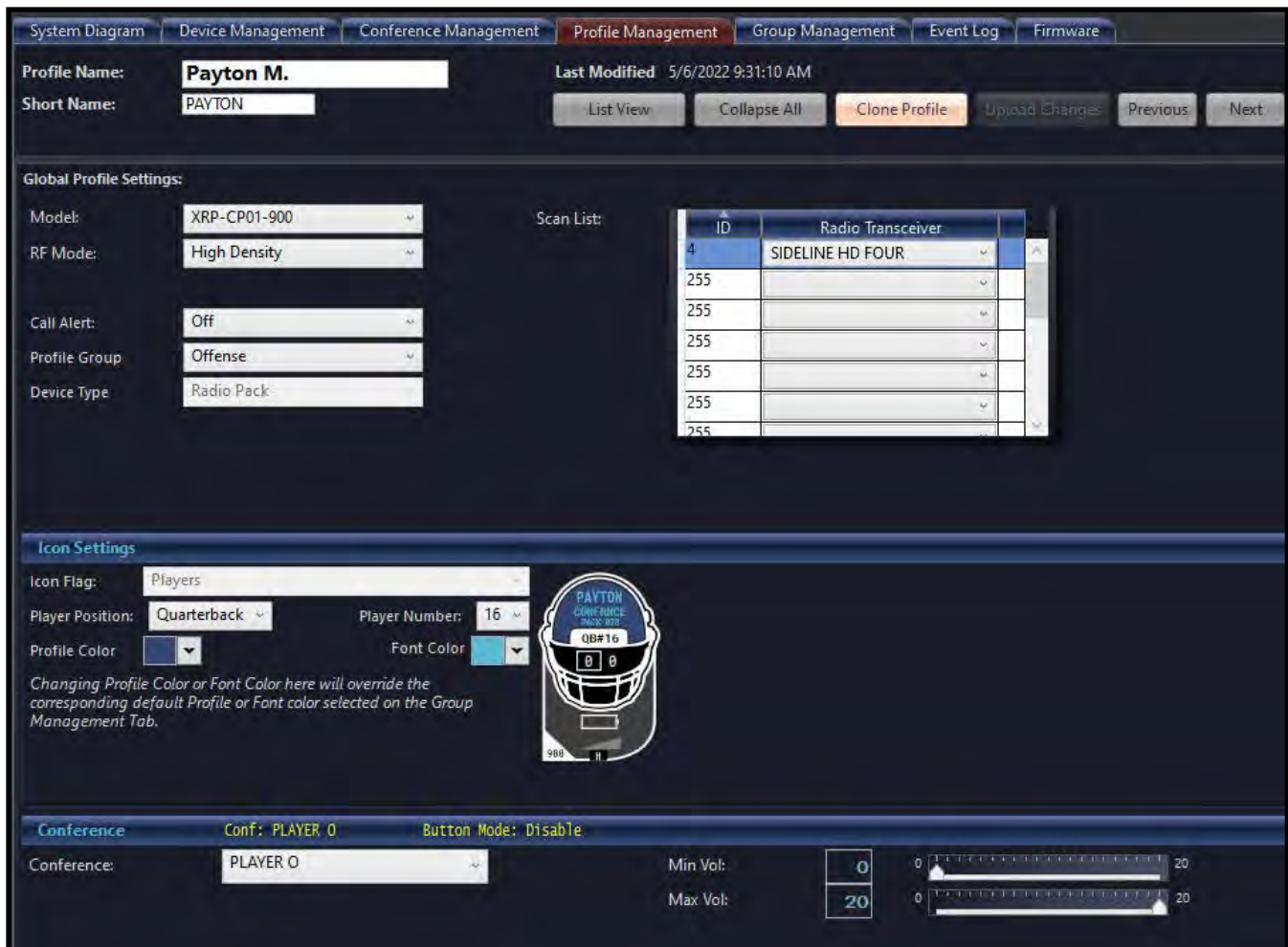

Figure 115: CoachComm X-System Player Profile Example

1. Select XRP-CP01-900 as the model (use this same selection for the XRP-CP01M-900 mini player module).
2. Set the RF Mode to either Normal or High Density mode (CoachComm recommends High Density mode if a large number of player modules will be paired to the X-System).
3. Customize the Player Position and Number in the Icon Settings. See Figure 115 for an example of an CoachComm X-System Player Profile.
4. Select the Player Conference.

See “Assign Profiles from the Control Unit” on page 34 and “Assigning New Profiles” on page 48 for information on assigning this profile to the CoachComm X-System Player packs (if not selected when pairing in the next section).

Pair with X-System

1. Connect to bottom CU. Using the supplied USB-C to USB-A cable, plug the cable into the USB-C connector on the CoachComm X-System Player and into the USB-A connector on the bottom CU.
2. Follow CU prompts. Follow the normal pairing procedure on the LCD screen of the CU. Choose a profile from the list by scrolling left/right, then enter. When paired, the display will read “Pairing complete.”



Figure 116: Select Player Profile on CU

Note: The STATUS LED on the CoachComm X-System Player will flash AMBER when pairing is complete. If the STATUS LED is RED, the CoachComm X-System Player is not paired.

Coach Radio Pack Operation

On a coach RP, press the Function/Talk button that is assigned to the player conference. Audio will be sent to only those player modules and coach RPs with the player conference assigned.

CoachComm X-System Player Operation

Charge and Power On

1. Connect battery to CoachComm X-System Player. Make sure the arrows on the two connector ends are aligned.
2. Connect CoachComm X-System Player to charger. With the supplied USB Charger and USB-A to USB-C cable, connect to the Charging Connector on the CoachComm X-System Player. The POWER LED will be flashing green during charging and green when fully charged.

Note: The battery cannot be charged without being connected to the CoachComm X-System Player. Battery charge time should be approximately three and a half (3.5) hours.

3. Ensure the CoachComm X-System Player has been fully charged.

Note: The CoachComm X-System Player automatically powers down after approximately five (5) minutes of inactivity if it does not detect movement and is not connected to a system to conserve battery power. Shake CoachComm X-System Player for three seconds until the GREEN POWER LED comes on.

Assemble Parts

1. Attach speaker assembly. Connect the Speaker Assembly to the speaker connector on the CoachComm X-System Player. Check the Speaker Assembly is snapped into place and is securely connected to the CoachComm X-System Player.
2. Attach velcro to CoachComm X-System Player, battery, and speakers. Attach the “hook” side of the velcro onto the CoachComm X-System Player module components, and attach the “loop” side of the velcro to the helmet.

Note: The rectangle velcro should be attached to the CoachComm X-System Player and battery on the non-label side. The circle velcro should be attached to the speakers on the side without speaker holes.

Determine Placement of Components



WARNING: To prevent SERIOUS INJURY or DEATH, ALWAYS contact the helmet manufacturer for the approved device placement locations for the Radio Pack and its accessories. These may vary between helmet models and between helmet manufacturers.

1. Adjust volume to lowest level. Before installing the CoachComm X-System Player and Speaker Assembly, turn the volume to its lowest level using X-Ware.



CAUTION: HEARING LOSS HAZARD. To prevent possible permanent hearing loss, ALWAYS set the volume as low as possible depending on the ambient noise at practice or at a game.

- » DO NOT use Radio Pack if it emits any unusual loud noise. Turn Radio Pack off and contact CoachComm Customer Service.
- » Permanent hearing loss may result from exposure to high volumes or other loud noises.

2. Follow the recommendations of the helmet manufacturer for the specific model helmet.

Power Off

Auto Sleep: Player module automatically goes into a sleep/low-power mode after approximately five (5) minutes of inactivity if it does not detect movement and is not connected to a system to conserve battery power.

Power Off: Unplug the CoachComm X-System Player Rechargeable Battery from the battery connector.

Note: Charge the CoachComm X-System Player battery after each use. Disconnect battery if storing for more than a week.

Product Care

To prevent damage to X-System Player Module:

- Never use cleaners that contain solvents.
- Keep liquid and foreign objects out of the device openings.
- If the product is exposed to rain or moisture, gently wipe off all surfaces, cables, and cable connections as soon as possible and allow unit to dry before storing in your case.

After each use:

- Power off all X-System Player Modules. Thoroughly dry off any moisture. Properly stow all gear in your case.
- Fully charge battery.
- Clean using a soft, damp cloth if needed.

CoachComm X-System Player Module Specifications

Specification	CoachComm X-System Player	CoachComm X-System Player Mini
Length:	1.875 in.	4.7 in. (with antenna), 1.86 in (module body)
Width:	2.75 in.	1.45 in.
Height:	0.625 in.	0.4 in.
Weight	0.25 lbs (113 g)	0.19 lbs (86 g)

X-System Referee Cutoff

As part of the CoachComm X-System Player workflow and integration, CoachComm has built in the ability to accommodate a referee cutoff or mute function. This function will mute all communication to CoachComm X-System Player modules (for both teams in a game day environment) through the use of a Referee Cutoff Switch that can be connected either wired or wireless through an existing X-System. Through the referee cutoff function, officials now have the ability to ensure that both team’s player communications have been cutoff for the designated period of time. To add confidence that the CoachComm X-System Player modules are being muted, a confidence indicator light has been added that should be installed on a Radio Transceiver (RT) located on the X-System’s mast. By mounting the very bright LED light on an RT, all coaches, players, and even fans will be able to see when communications to the player have been stopped.

Components

See Referee Cutoff Block Diagrams for images of components.

- XRP-13 with a Referee Profile assigned

Note: A Referee Profile cannot be assigned to a XRP-22 and XRP-44.

- Referee Cutoff Switch (CAC-REFSW-01)
- Confidence Indicator Light Kit (Includes bulb) (CAC-CONFLITE-01)
 - » Confidence Indicator LED Bulb Kit (2 Bulbs & 2 Packs Grease) (CAC-LEDBULB-KIT)
- Cables
 - » 4-Foot 4-Pin Female XLR to Ethercon for Single Wireless Ref Cutoff Configuration (CAB-4FE-04)
 - » 3-Foot Dual 4-Pin Female XLR to Single 4-Pin Male XLR Y Cable for Dual Ref Cutoff (CAB-4FY4M-03)

Referee Radio Pack LCD

Home Operating Screen



Figure 117: Referee Radio Pack Home Operating Screen

Note: The screen will display “No Switch Connected” when there is no switch connection to the headset input.



Figure 118: Referee Radio Pack Switch Not Connected

Secondary Operating Screen

Since there is no menu on the Referee Radio Pack, holding down the Menu button will access the Secondary Operating screen.

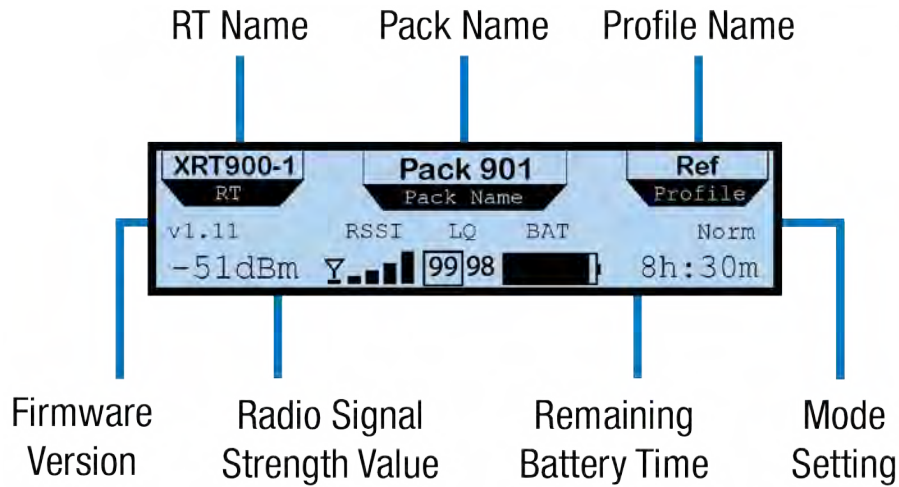

Figure 119: Referee XRP Secondary Operating Screen

Adding a Referee Profile

See “Adding a Profile” on page 56 for information on how to add a profile in X-Ware. When adding the Referee profile, choose Referee Interrupt Device as the device type. See Figure 120 for an example of a Referee Profile.

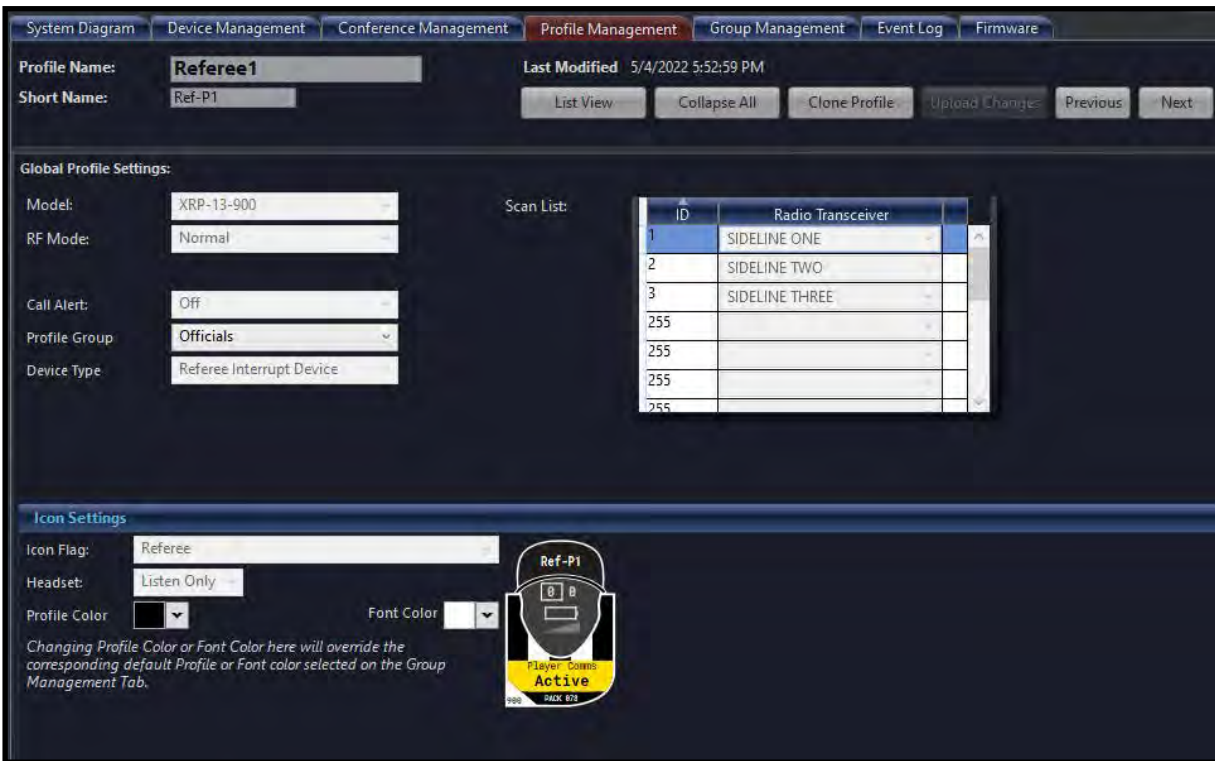

Figure 120: Referee Profile Example

See “Assigning New Profiles” on page 48 for information on assigning this profile to the pack that will function as the Referee Cutoff.

Note: Referee Radio Packs cannot be unpaired from X-System through right clicking the pack in X-Ware. Unpairing must be done through the CU.

Player Communications Mute Indication

X-Ware

When coach to player communication is muted, the communication status indicator at the bottom of the screen, the player pack icon, and the referee pack icon (“Figure 61: X-Ware Referee RP Icon” on page 46) will show “Muted” on a red icon flag.

Referee Radio Pack

When coach to player communication is muted, the Referee Radio Pack will display “Player Comms MUTED” on the primary screen.



Figure 121: Coach to Player Communications Muted Icons



Figure 122: Referee Radio Pack Player Comms Muted

Operation

Referee Cutoff can be triggered via the Referee Cutoff Switch or the Referee Radio Pack Function Buttons.

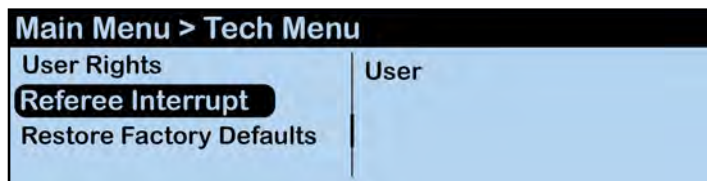

Figure 123: Referee Cutoff Trigger

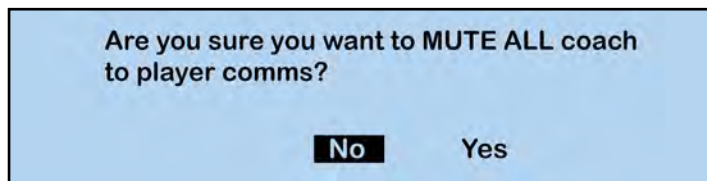

Figure 124: Referee Radio Pack Function Buttons

In case of hardware (referee cutoff switch) failure, Referee Cutoff can be set to NORMAL or MUTED from the front panel of the CU. In the Main Menu, select Tech Menu > Referee Interrupt.



Set to MUTED.



Coach to Player Cutoff Tones

By default, a series of descending and ascending tones will be sent to wireless users when Coach to Player (C2P) cutoff is engaged and disengaged. To change the volume or turn off tones from the XRP, press and hold the triangle menu button. Navigate to User Settings > C2P Tones and select High, Medium, Low, or Off. The default volume is Medium.

For wired connectivity between the field and the coach's box, to turn on the tone and/or set the volume, access the Intercom Settings in the Wired Settings of the CU as shown in the figures to the right.

Setup Notes

For wired connections, the tone is sent only to the selected hardwire ports. Mute/Unmute tones are sent to wired connections, but they will not receive "Busy" tones.

Wired connection tone settings do not get saved with the CCF, are not available in software, will stay on CU for PWR On/Off, and only reset upon factory reset or deletion of CCF.

Mute / Unmute Indication

- Descending Tones when engaged
- Ascending Tones when disengaged

Busy Tones

When the C2P function and Referee Cutoff are BOTH engaged, a busy tone of fast beeps will be heard on the wireless pack (XRP-13 only).

Who Hears the Tones?

- Wireless packs that have C2P Conferences assigned to their function button(s)
- On the field and Wireless Press Box Coaches
- Wired users who have the tones assigned to C2P Conferences (Mute / Unmute Tones Only)
- Wireless Press Box users who are using dry pair instead of fiber and have tones assigned to C2P Conferences (Mute / Unmute Tones Only)

NOTE: There are no tones if the C2P conference is assigned to a Conference/Talk button instead of a function button.

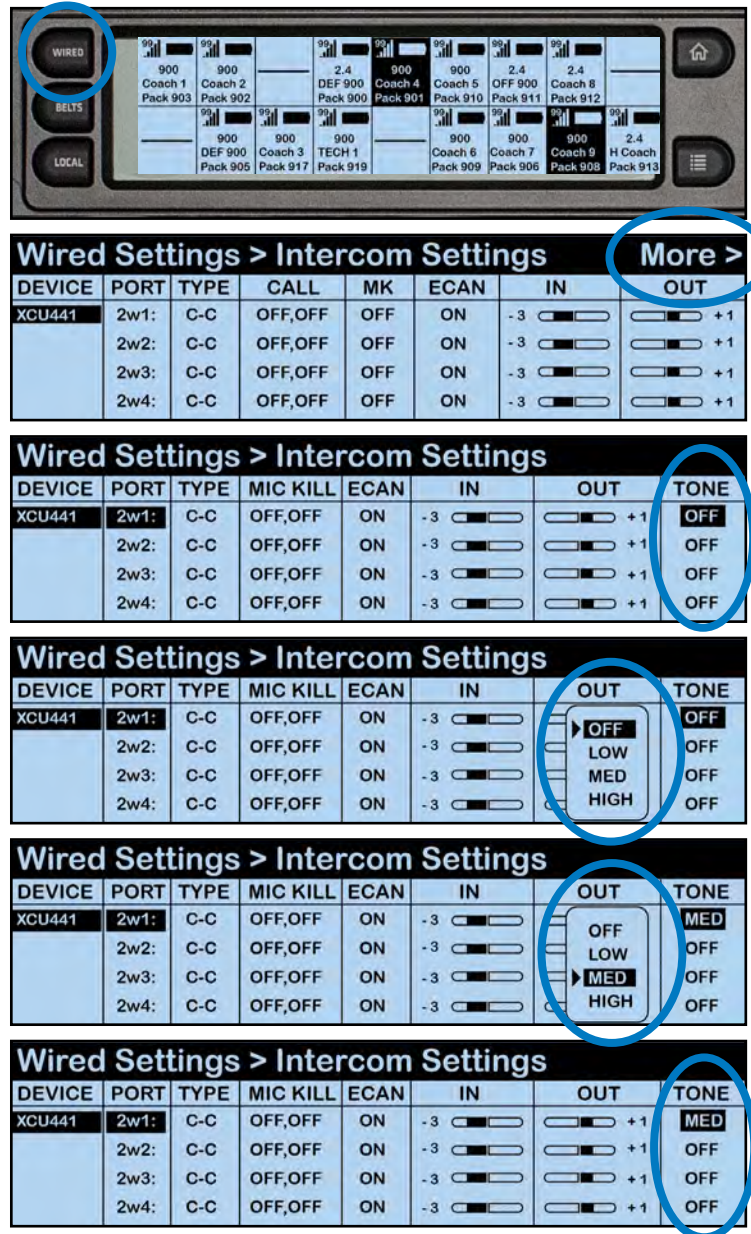

Figure 128: Change Tones in Intercom Settings on Control Unit

Referee Cutoff Cable Configuration Options

Note: Cable lengths are not to scale.

Single Wireless

See Figure 109 on page 83.

Unless two X-Systems are synced together, the Single Wireless configuration will only mute coach to player communication for one sideline's X-System (Home or Away). The other sideline X-System will require a separate Referee Cutoff cable configuration for muting player communications (Single Wireless or Wired).

Dual Wireless

Unless two X-Systems are synced together, the Dual Wireless configuration will mute coach to player communication for both sidelines' X-System (Home and Away). The Referee Cutoff Switch is connected to two Referee RPs via cable; one RP is paired to each sideline's X-System.

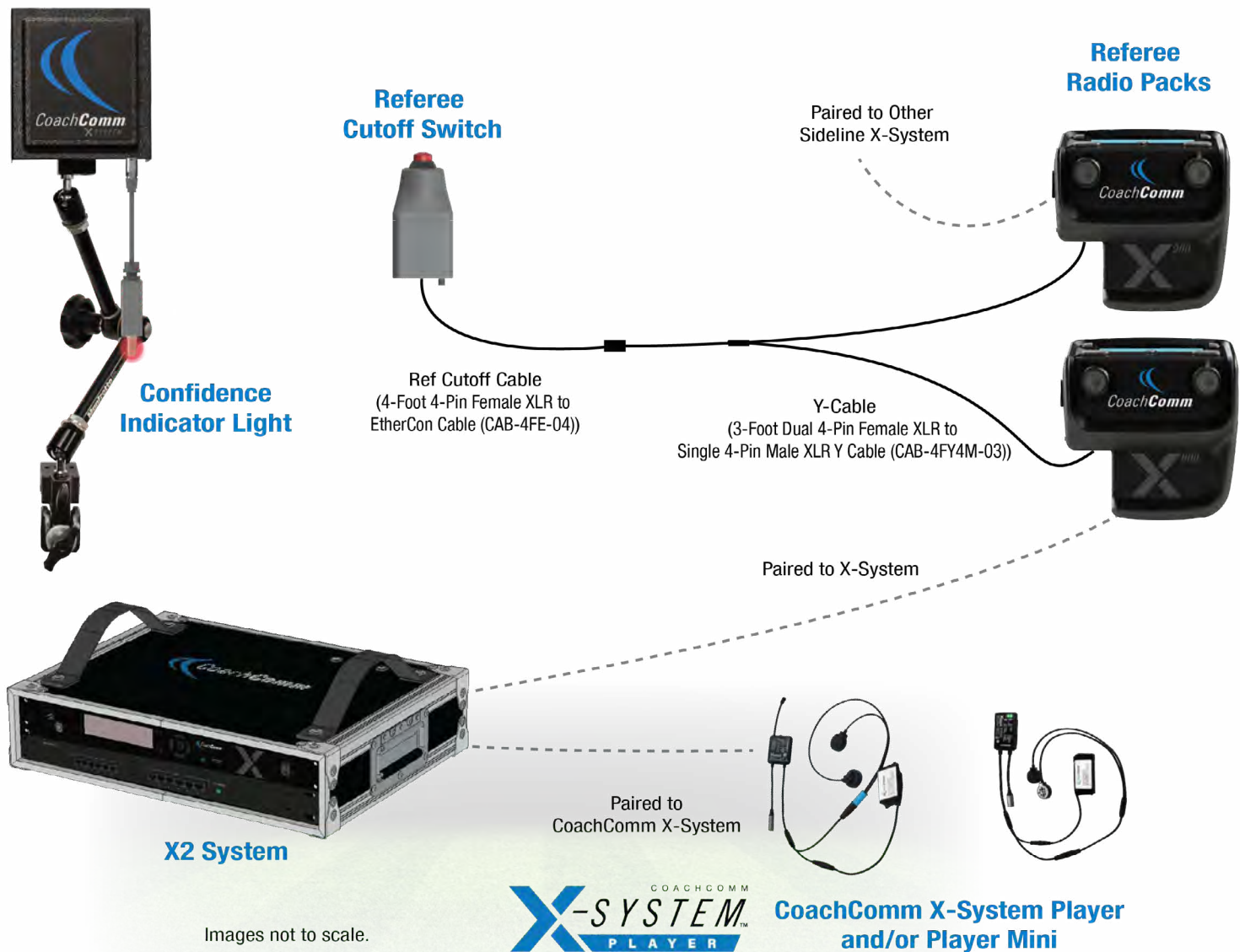

Images not to scale.

Figure 125: CoachComm X-System Player Block Diagram (Dual Wireless Referee Cutoff Configuration)

CoachComm to GSC Referee Cutoff Integration

1. Connect the 4-Pin Female XLR from the Extender cable (10, 30, or 100 feet) into the OUTPUT connector (4-Pin Male) of the GSC Panel.
2. Connect the 4-Pin Male XLR from the Extender cable into the 4-Pin Female XLR connector on the CoachComm In-Line Interface.
3. Connect the EtherCon connector from the CAB-4FE-04 into the CoachComm In-Line Interface.
4. Connect the 4-Pin Female XLR from the CAB-4FE-04 into an XRP-13 Radio Pack (w/Referee Profile).

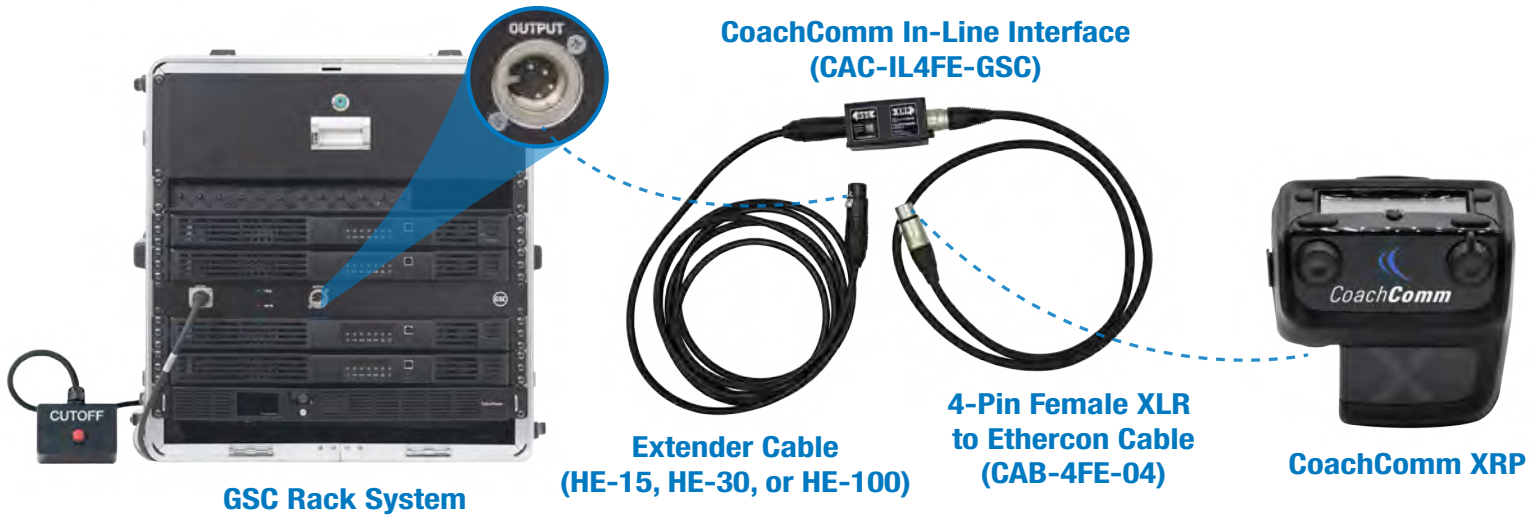

Figure 126: CoachComm to GSC Connection Diagram

Note: Separate CoachComm XRP from the GSC Rack and Antennas by at least 10 feet.

Appendix B: All Wireless Press Box

System Deployment - Radio Transceiver (RT)/Antenna Placement

- Mount the Field RTs at a 90° orientation to the Booth RT outside/open window (preferred/optimal)
 - » Pointed at the appropriate sideline (Image shown to far sideline)
- Mount the Booth RT at 90 degree orientation to the Field RTs
 - » Pointed across booth “working area” at the same end of press box
- It’s very important to maximize the vertical distance between the Field RTs and the Booth RTs



Figure 127: All Wireless System RT Placement



CoachComm LLC
205 Technology Parkway
Auburn, Alabama 36830
1.800.749.2761
www.coachcomm.com

Copyright © 2018-2026 CoachComm LLC. All rights reserved. SmartBoom®, CoachComm X-System®, and CoachComm X-System Player™ are registered trademarks of CoachComm, LLC. Any and all other trademark references within this document are property of their respective owners.

Document Reference: D0000383_N