

SMARTBOOM® PRO

>> The most trusted and used coaching headset

The SBP Headset from CoachComm provides exceptional comfort and reliability while introducing advanced features and design enhancements.

The SBP Headset features SmartBoom technology, allowing the microphone boom to act as an On/Off switch for quick microphone muting. Additionally, the headset provides high ambient-noise reduction and produces high quality audio using a hyper-cardioid dynamic microphone. The SBP headset delivers the quality you expect from CoachComm along with a flexible design and soft padding to offer superior comfort.



SBP-191

The ONLY headset featuring SmartBoom technology and a sleek, design ideal for sponsorship branding.

www.coachcomm.com

FEATURES

- SmartBoom® Technology - Raising the Boom Mutes the Mic
- Sleek, Low Profile Design Available in Single- and Dual-Ear Models
- Flat Surface Areas Provide Ample Branding Space for Sponsors
- Outstanding Audio Quality with Enhanced Acoustic Isolation
- Dynamic, Noise-Cancelling Cardioid Microphone
- Rubber Coating Provides Enhanced Design and Durability
- Collapsible Design for Easy Storage
- Flexible, Ambidextrous Swiveling Mic Boom
- Detachable Cable Allows for Quick and Easy Field Repairs and Connector Options
- Soft-Padded Ear Pads and Head Pads can be Easily Replaced
- Cable Terminated with 4-PIN XLR Female



SBP-192

WIRING DIAGRAM FOR CONNECTOR INPUTS

PIN CONNECTIONS		
Headset Plug Pin	Cable	XLR Plug Pin
8	Blue – Speaker R+	4
7	Brown – Speaker L+	4
6	Red – Speaker R-	3
5	Orange – Speaker L-	3
2	Yellow – Mic+	2
1	Green – Mic-	1
3	Uncoated – Shield	1
4	No Connect	NC

SMARTBOOM® PRO HEADSET

» Specifications

Microphone

Microphone Type	Dynamic
Frequency Response	50–10,000 Hz
Mic Sensitivity	-58 dBV/Pa
Pattern	Cardioid uni-directional
Output Impedance	200 Ω
Isolation from Headphone	40 dBv

Speaker (Headphone)

Frequency Response	20–20,000 Hz
Nominal Impedance	100 Ω
Sensitivity at 1 kHz	
Single	117 dB SPL/mW
Double	121 dB SPL/mW
Speaker Type	Dynamic
Max Input Power	500 mW

Cables

Termination at Ear	Removable (Crossbolt)
Termination at Jack	4-pin XLR Female
Length	5.00 ft. (1.52 m)
Outside Diameter	0.24 in. (6.00 mm)

Physical Features

Outer Ear Cup Surface Diameter	
With Boom	2.40 in. (60.96 mm)
Without Boom	3.17 in. (80.52 mm)
Mic Boom Length	8.50 in. (215.90 mm)
Weight (without cable)	
Single	8.1 oz (229.63 g)
Double	11.4 oz (323.18 g)
Cable	3.8 oz (107.73 g)

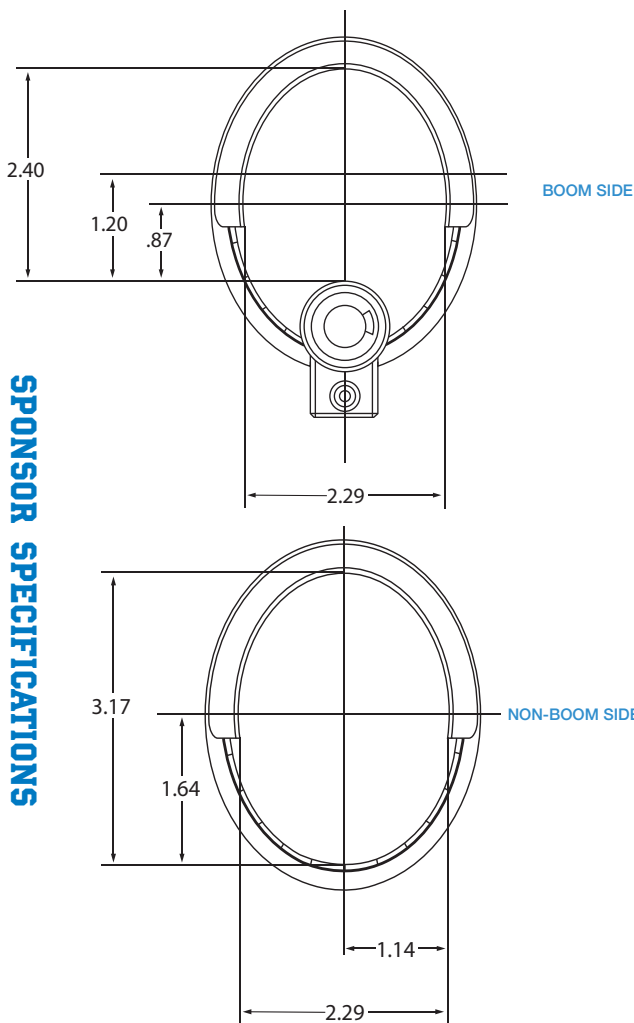

MEASUREMENTS IN INCHES

SPONSOR SPECIFICATIONS

Manufacturer reserves the right to change specifications to reflect latest changes in technology and improvements at any time without notice.

©2015-2020 CoachComm, LLC. All rights reserved. CoachComm and SmartBoom logos are registered trademarks of CoachComm, LLC.

SBP-191_192_CUTSHEET_2020



205 Technology Parkway
Auburn, AL 36830
1.800.749.2761

www.coachcomm.com