

Getting Started

This Game Day Guide is a basic reference for setting up your CoachComm X-System. For complete operation instructions, see the *X-System Operating Manual*, which is available on CoachComm's website at: www.coachcomm.com/x-system-support.

CAUTION: Allow only responsible, authorized individuals who have read all of the instructions and warnings to set up and operate your X-System.

Provided Tools:

- 1/2" socket wrench
- Drill bit adapter (1/4" hex to 1/2" square) for use with any 1/4" drill or cordless screwdriver

Additional Tools You May Need:

- 1/4" drill or cordless screwdriver

Required Power Connection:

- Minimum of one dedicated 15 amp 120V circuit

Sideline Cart Overview

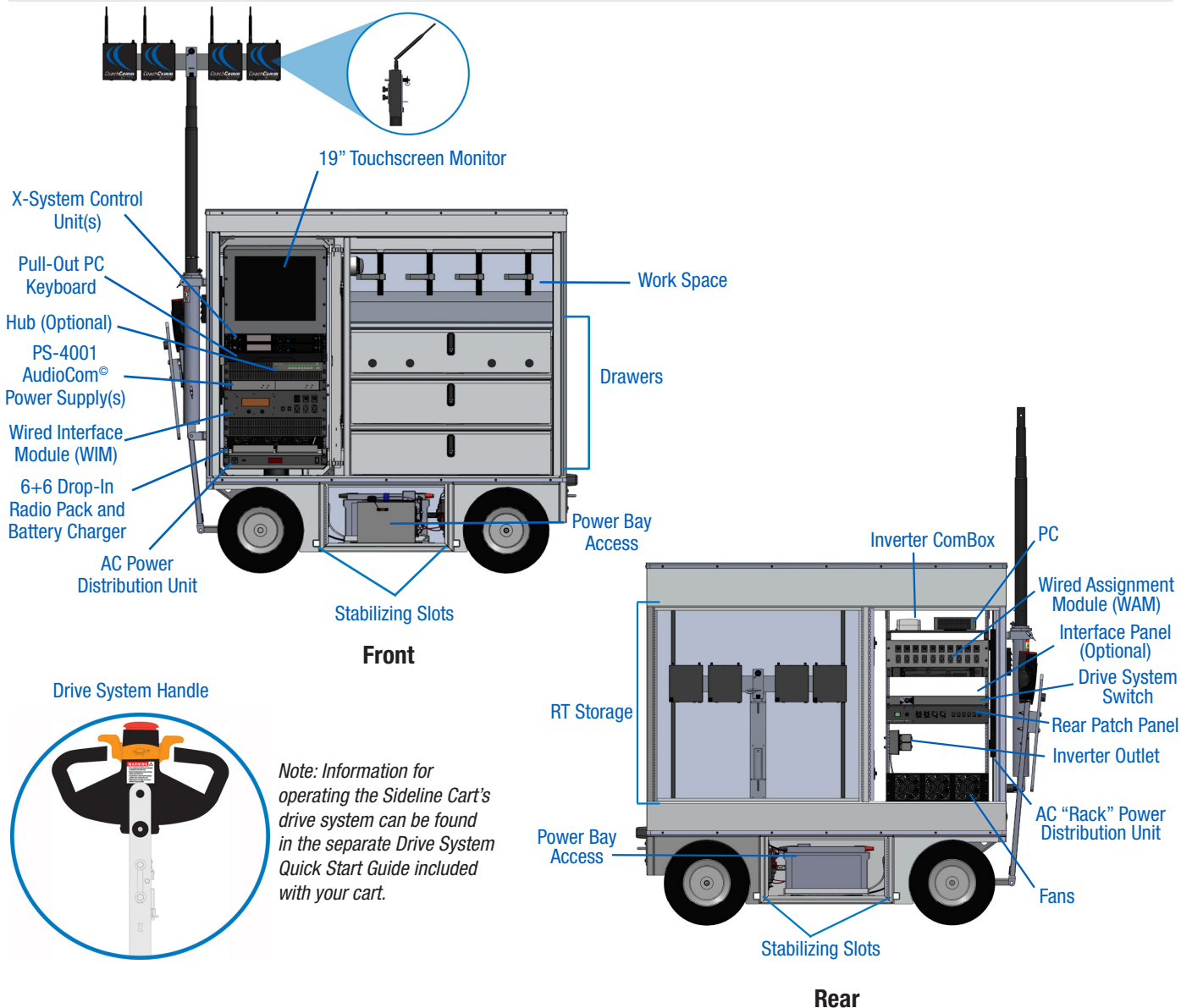

1 Position and stabilize cart.

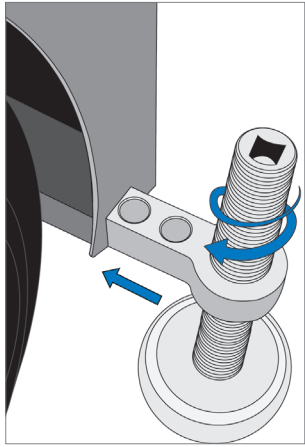

- 1a. Once the cart is positioned at midfield, **insert each of the four stabilizers** into their associated slots.
- 1b. **Extend the stabilizers** to the ground using either the socket wrench or the drill bit adapter and drill. Continue extending until stabilizers have made sufficient ground contact to stabilize the cart.

Note: The cart stabilizers are not intended to lift the cart.

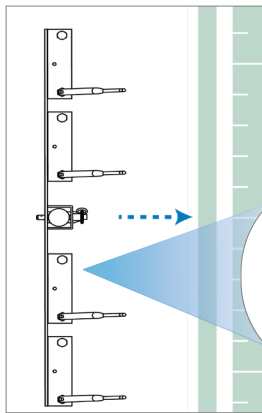

Align mast so RT bracket(s) will be parallel to the sideline.

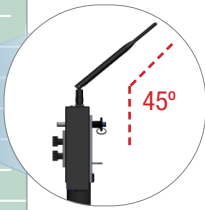

(2c.) Secure tube while removing Pins 2 & 3. Lower to ground.

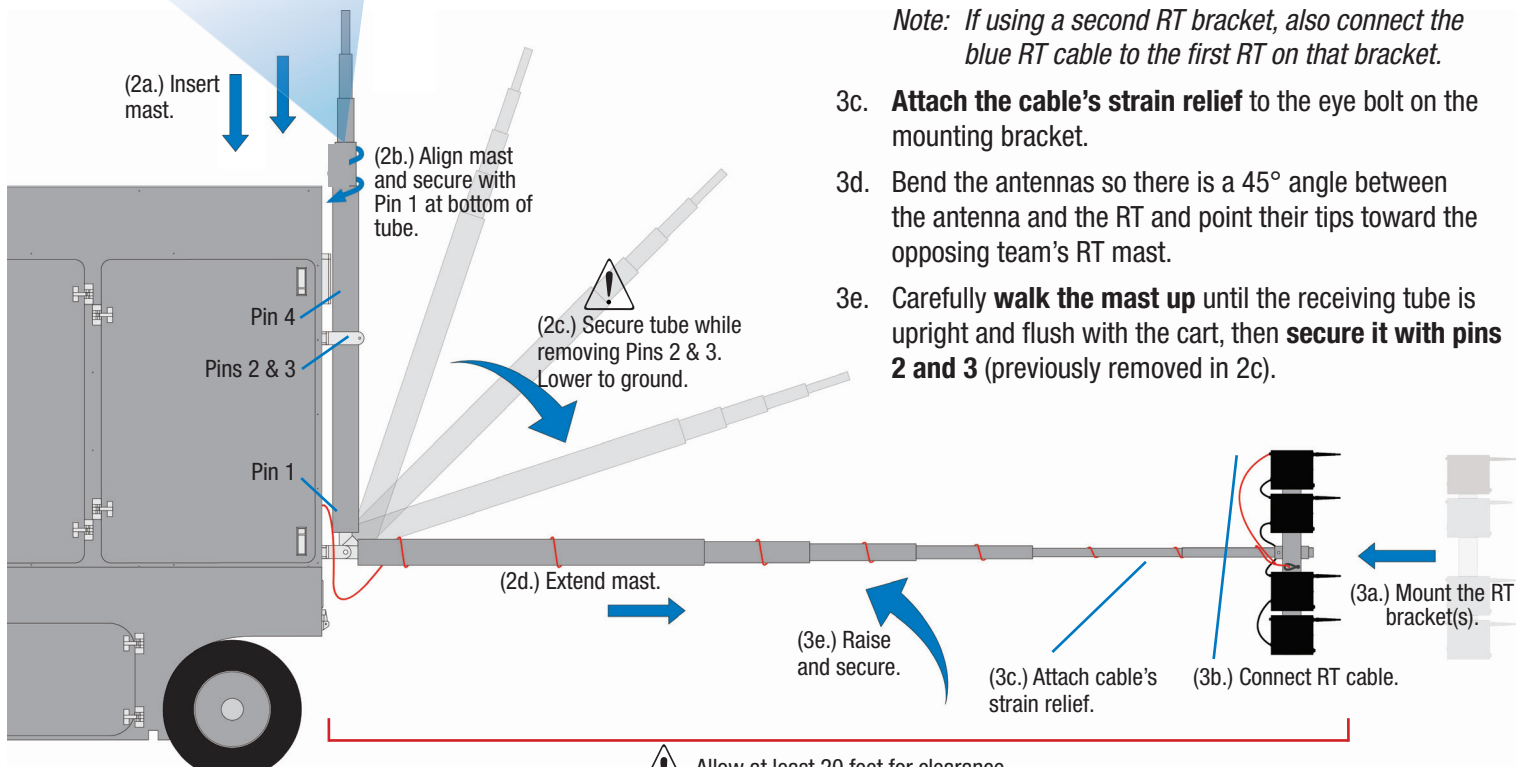

⚠ Allow at least 20 feet for clearance.

2 Prepare RT mast.

The procedures in this step are referenced in the figure below and should be performed with at least two people.

- 2a. Remove the mast from its storage area and **insert it** into the locked and upright mast receiving tube.
- 2b. **Align the mast** so your RT mounting bracket(s) (when attached) will be parallel to the sideline and **secure it with pin 1** at the bottom of the tube.
- 2c. **Secure the mast** and tube with one hand, then **remove pins 2 and 3** from the top of the tube. Carefully **lower the mast** to a bench or chair level with the cart.
- CAUTION: Ensure there is a minimum of 20 feet of clearance beside the cart before lowering the mast.*
- 2d. **Extend the mast to the desired height**, locking each section in place. (A minimum of 12 ft. is recommended.) Use pin 4 to secure any non-extended sections.

3 Mount RTs and secure mast.

The procedures in this step are referenced in the figure below and should be performed with at least two people.

- 3a. **Mount the RT mounting bracket(s)** to the top of the mast using the provided pins.
- 3b. **Connect the red RT cable** to the first RT on the top bracket.
- Note: If using a second RT bracket, also connect the blue RT cable to the first RT on that bracket.*
- 3c. **Attach the cable's strain relief** to the eye bolt on the mounting bracket.
- 3d. Bend the antennas so there is a 45° angle between the antenna and the RT and point their tips toward the opposing team's RT mast.
- 3e. Carefully **walk the mast up** until the receiving tube is upright and flush with the cart, then **secure it with pins 2 and 3** (previously removed in 2c).

4 Connect RT cable and dry pair to cart.*

- 4a. **Connect the red RT cable** to the “TOP RT SET” port on the cart’s rear rack patch panel.
Note: If using a second RT bracket, connect the blue RT cable to the “BOTTOM RT SET” port.
- 4b. **Connect stadium’s dry pair panel** to the corresponding “STADIUM DRY PAIR” ports on the rear patch panel. (You can find additional instructions about dry pair connections in the *X-System Operating Manual* found at www.coachcomm.com/x-system-support.)

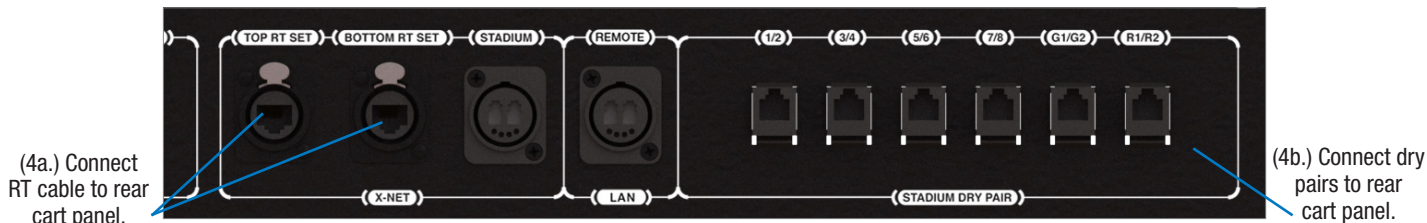

*Fiber connections not shown here. For more information about fiber, refer to the Wireless Press Box Game Day Guide or X-System Operating Manual.

5 Connect AC power and power on the cart.

- 5a. **Route an external power extension cord** through the cart’s hatch and connect it to the main AC power cord in the rear of the cart.
CAUTION: *Secure and protect any cords to prevent walkway hazards and potential contact with moisture.*
- 5b. **Power on the cart** via Master On/Off switch on the cart’s rear panel.
- 5c. **Confirm** that all devices on the front rack are powered on, including the AC power distribution unit, Control Unit(s), and monitor.

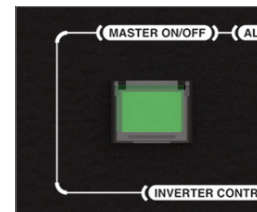

(5b.) Power on the cart.

6 Set Home/Away status.

- 6a. Follow the prompts on your top (primary) CU to set your system’s Home/Away status.
Important: *No RF transmission will occur until the Home/Away status is selected. Failure to set this status properly may result in RF interference.*

The Home/Away setting aids customers with hopping pattern coordination between RTs and Radio Packs. Based on this setting, all of the RTs on the system will be assigned specific hopping patterns by the Control Unit (CU). It is very important to set this status correctly. Hopping pattern coordination improves operation between X-Systems.

During startup, the configuration file (CCF) will begin loading while the Home/Away prompt is displayed on the top CU. A progress bar shows the load process on the bottom CU. Once the Home/Away prompt is cleared, the CCF load progress can be seen on both CUs.

- 6b. Wait until the CUs display the “CCF Loaded” message, along with a configuration file summary. (The bottom CU will take about 30 seconds longer than the top.) When the CCF load is complete, the home screen will display on the front of the CU(s) and you can proceed.
- 6c. Open X-Ware and allow its Home screen to load.

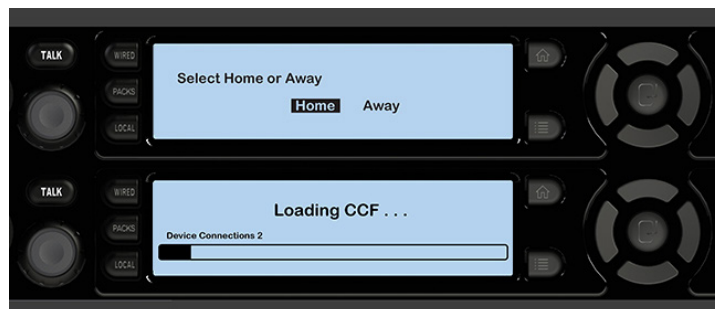

7 Set up Press Box Unit and null system.

The procedures in this step should be performed with at least two people.

- 7a. Once the sideline cart is configured, **set up and connect power to the Press Box Unit**. Have someone stay with the sideline cart to assist in the verification of dry pairs during this step.
- 7b. **Connect dry pair panel** in the Press Box to the corresponding ports on the rear of the WIM in the Press Box Unit.
- 7c. **Connect wired BeltPacks and cables** for each coach. Make sure all TALK buttons are off.
- 7d. **Auto-null** all of the lines from the sideline using X-Ware's Conference view (under the System Settings menu). If there is noticeable echo on some channels of the wireless components, confirm that all TALK buttons are off and repeat the auto-null step.

8 Power on and walk test Radio Packs.

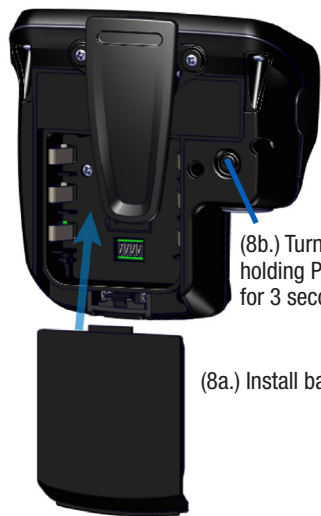

The procedures in this step should be performed with at least two people.

- 8a. **Install** a fully charged Lithium-Polymer rechargeable battery or three AA alkaline batteries in each Radio Pack (RP).
- 8b. **Power on the first two RPs** by pressing and holding the Power button on the back of the RP for 3 seconds.
- 8c. Confirm each RP is on the same conference, connect a headset to each RP, and **conduct a walk test** to confirm their operation. The RP's LQ value can be used to gauge performance.
- 8d. After walk testing is complete, **place the RP down on a table or bench**. Be sure to place each RP a foot or so apart; bunching RPs together could impact wireless performance. Repeat steps 8b-8c for each of the remaining RPs.
- 8e. **Connect batteries and speakers** to all CoachComm X-System Player Modules to turn them on. **Walk test the entire field** with players above shoulder height. Repeat walk test for all remaining Player Modules.
- 8f. **Confirm communication** between wireless and wired coaches.

9 Power off and stow away X-System.

Once your event has ended, power off and properly stow away all X-System sideline cart components:

- 9a. **Power off all RPs** and stow them in their drawers.

Important: *Thoroughly dry off any moisture prior to storage.*

- 9b. CoachComm recommends **saving a backup copy** of your system configuration file to the PC desktop or a USB drive. **Then, close X-Ware and shut down the PC.**

- 9c. **Power off the CU(s) then the cart's Master On/Off switch** on the rear panel. Unplug and remove your extension cord.

- 9d. Carefully **lower, disassemble, and stow the RT mast and RT mounting bracket(s)**, stowing them in their assigned sections of the cart.

CAUTION: *Maintain safe control of the mast and receiving tube throughout disassembly.*

- 9e. **Reinstall pins 2 and 3** once the mast is removed and the receiving tube is returned to its cradle.

- 9f. **Remove the four cart stabilizers**, then stow them in their assigned sections of the cart.